



## **A-level Product Design**

### **Innovative Product**

Emily Sutherland

Candidate number: 6168

All photos outlined by this were taken by me.

Anything outlined with this is where a stakeholder/ end user is giving feedback or a review.



A video is there to be watched

# Investigation of the context

For our OCR Product Design A-level we have been challenged in making an innovative product. To do this I started by collecting ideas of a range of possible products or branches in which to make a product. I focussed on different **issues** within a variety of areas that I am personally interested in such as scouting & boating and technology in order to find some solution to solve/compromise with the issue at hand.



I asked my family, who all have the potential to be **end users** to discuss the ideas presented in my first mind map in order to gain some external advice to influence my design decisions. My parents are both scout leaders for different sections and my sister is a teenager who enjoys interior design. In conclusion they expressed a larger interest in **small spaces** and **technology**.

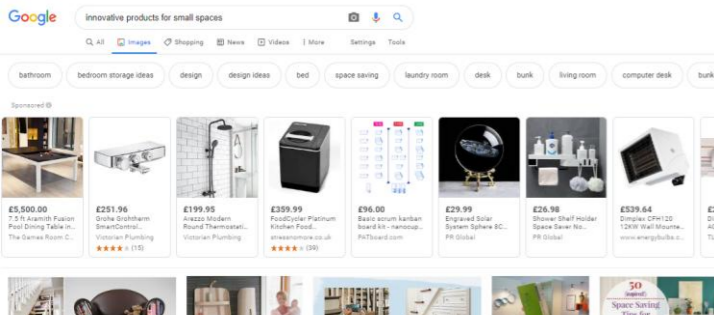
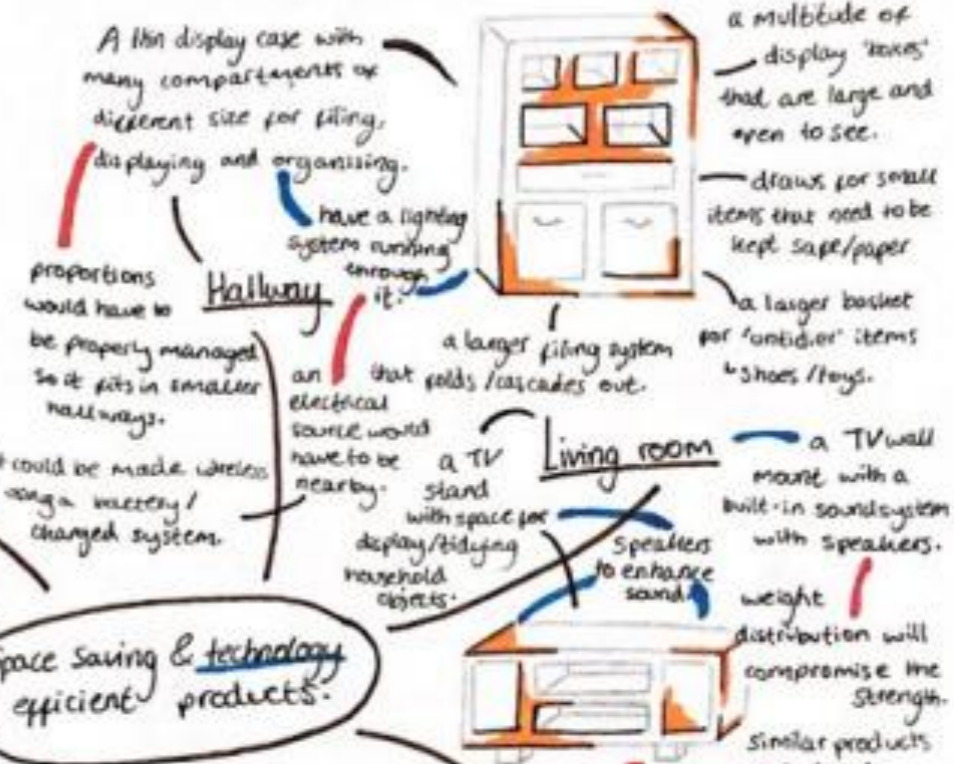
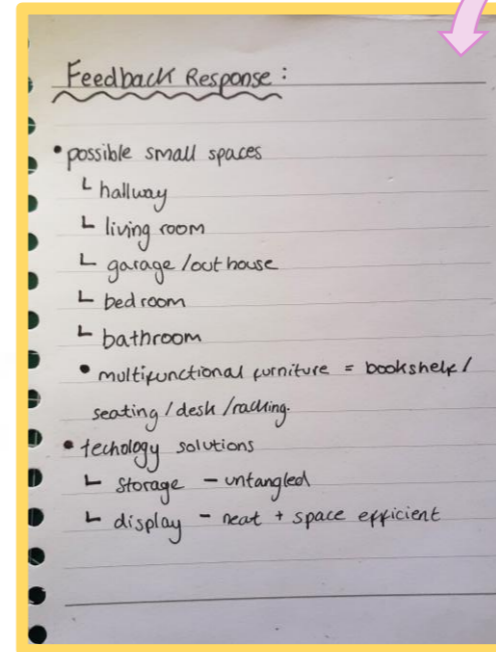
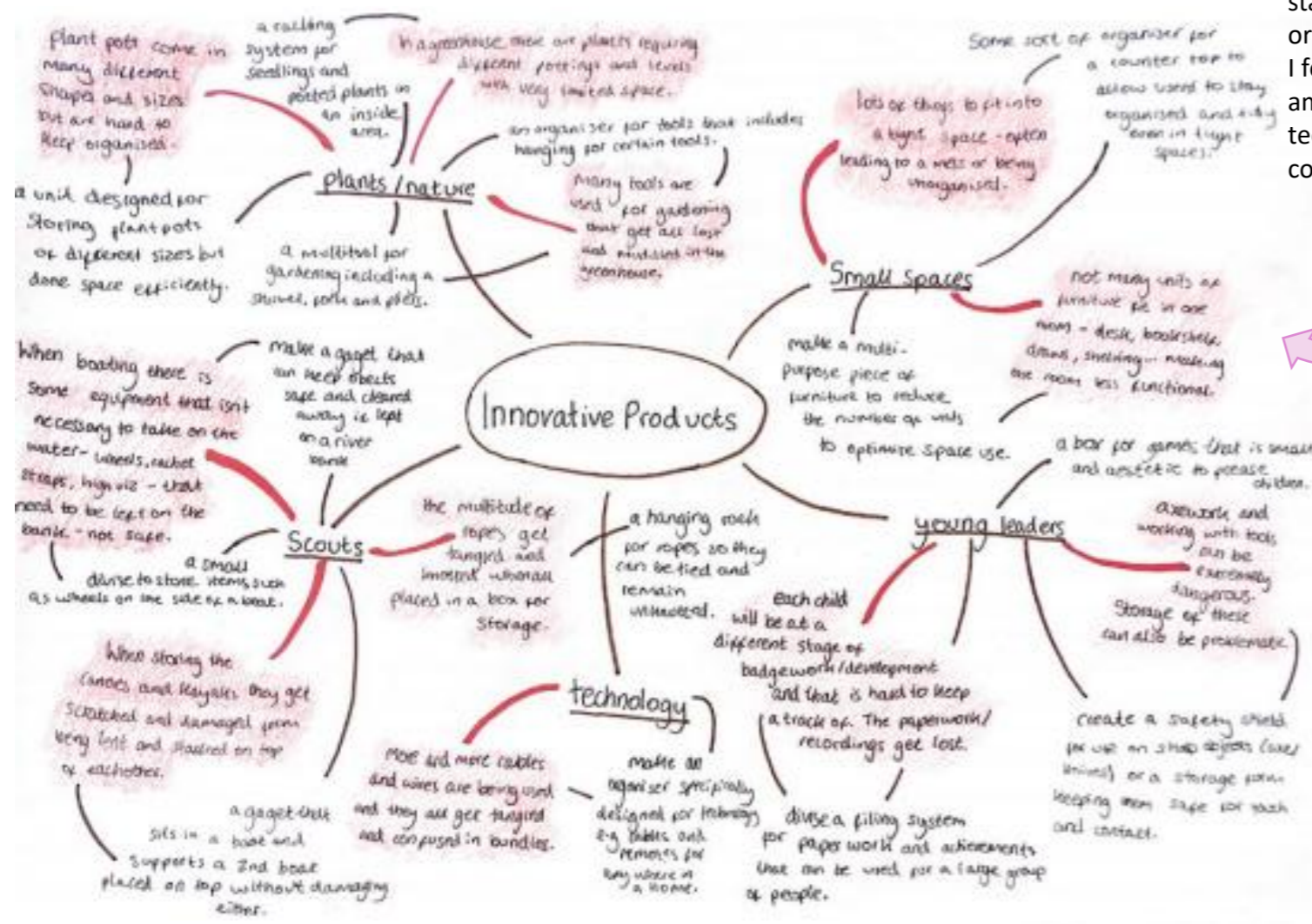

I searched to find any existing 'innovative products for small spaces' for inspiration.

I sketched out a standard unit which could typically be found in a bedroom or living room so that I could see what adaptations could be made to a simple product to make it more innovative.

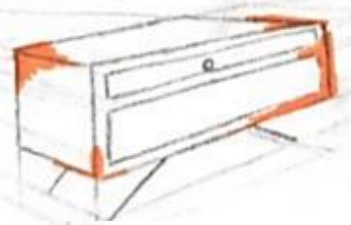

A pull out worktop could be added just above the draw to give it a bigger worktop surface area.

A charging station could be added in the draw or on the side.

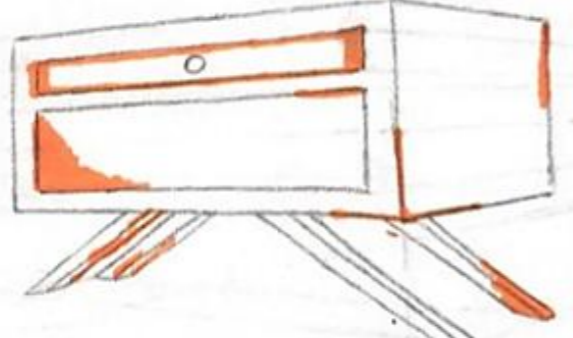

The larger compartment could be separated on the inside to make it more multi-functional with different sections.

Lighting rods could be added along the edges of the surface top and the inner edges of the draw and storage area.

**Next Step:** develop a more specific design brief that allows me to start developing a product.

# Design Brief

**Design Brief-** Design a product for a bedroom that sits beside or near a bed and provides organised storage space including storage for different technological appliances as well as being space efficient. It needs to be applicable to a large audience of any age with an innovative and practical design. It should be compact and easy to use for anyone with any physical ability. Its main use is to save people hassle in a multi-functional unit. Because of this, I will use a user focussed design process whereby I remain in contact with my primary users and stakeholders throughout the designing of my product.

National lockdown due to COVID-19 will limit my interactions with different stakeholders as it will all be done online or within my family. However, I will do my best to gain the opinions and requirements from a range of stakeholders.

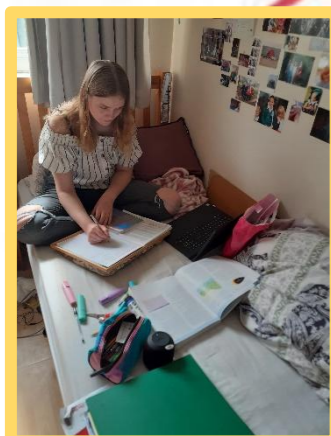

There is no form of back support other than pillows and the wall making it very uncomfortable for long periods of time.

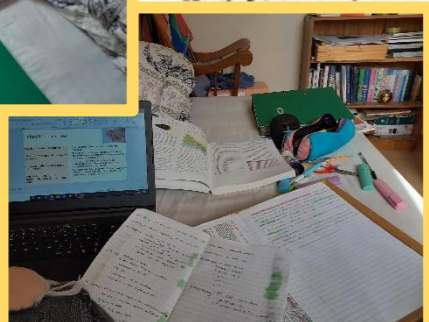

It is unorganised as items are just put on top of each other and lost around the bed.

Working on a bed

There is no steady space for safely using a laptop or ipad.

The laptop cable often gets lost or caught up in the work and there is nowhere to keep a memory stick where it won't get lost.

There is no firm surface to write on so external items have to be used - a pillowed tray.

These then have to be stored somewhere which is tricky with limited space.

All her appliances - extension cable, hair dryer, hair straightener, phone charger and fan are kept on the floor in an untidy pile.

Standard 22 year olds bedroom



a room for new furniture so there won't be a solution to the mess.

## Initial Technical Considerations:

- Height
- Weight Distribution
- Adjustable parts
- Component sizes:
  - Drawers
  - Baskets
  - Open sections
- Handle shapes
- Moving elements

**General Problems -** when exploring the design brief and context I have identified many different issues (usually indicated via ↖), across my mind maps.

These issues are all ones that would benefit from solutions so after I have explored the problems I will explore and develop solutions - hopefully numerous will be compiled into one product.

The main issues so far have been: space restrictions, appliances scattered across a room, unorganisation and wires getting tangled.

the surfaces are very cluttered with no means of organisation meaning it is a muddle and hard to find specific items when they are needed.

Standard 18 year olds bedroom

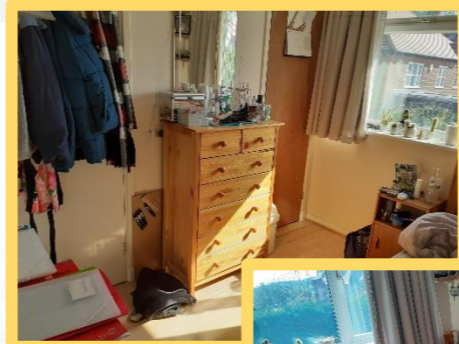

it is a tight space with 5 pieces of larger furniture which limit the usable space.

no place to work so has resulted to using the bed.

crowded surface tops covered in accessories, pictures, plants and paperwork.



## Other stakeholders

- people who work from home
- shop owners (furniture)
- interior designers (knowledge + understanding)
- people who use multiple appliances in their bedroom (females - hair products?)
- manufacturers (UK and abroad?)
- flat-pack furniture developers (distribution)
- schools (cabinet / desk)
- offices (filing + organisation)

very little floor space due to a lack of sufficient storage around the room.

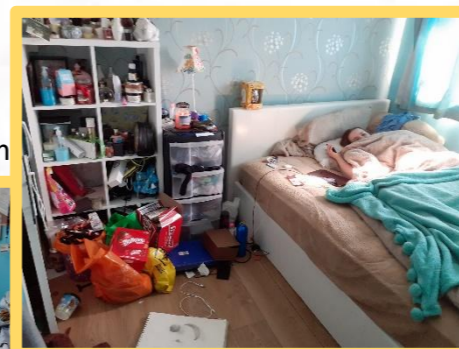

## Primary users

### Callan Wintle-

An 18 year old training in lighting engineering. He has worked with the **Henley theatre services** for 2 years offering 'a comprehensive range of equipment for hire covering generic and intelligent lighting, digital and analogue audio, video, staging, rigging and special effects.' I reached out to him because of his in depth understanding of technology which will help me develop an efficient solution to technology issues.



<https://www.henleytheatreservices.com/>

### Sophie Sutherland-

A fifteen year old school student studying GCSEs at Wallingford School. Her favourite subjects are: science and RS. She enjoys tidying her room and presenting it in

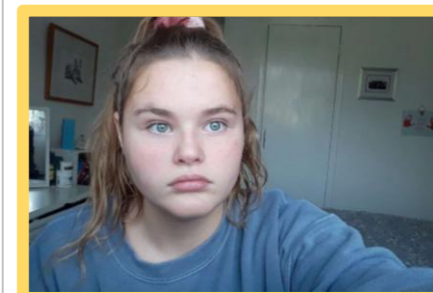

aesthetic ways with different pieces of furniture and decorations.

This makes her a good end user as she is likely to require and utilise a product with this description. Her input will allow me to strongly incorporate an end users opinion, wants and needs.

### James Sutherland

A fifty-four year old dad of 3. He has three teenage daughters whilst holding a high position at HR Wallingford. He has prior interactions with buying, building and positioning furniture in his 4 bedroom house so would be a good consultant into pricing range, likeable materials and easy construction methods all of which will be very useful to me.



This means that he is a viable stakeholder as he is likely to source or search for a product meeting this criteria either for himself or a family member.

**Next Step:** look at similar products in a typical house and analyse the strength and weaknesses of them.

# Existing Products & design practices- first hand research

This unit is short yet has 3 compartments for different storage- one open section and 2 draws beneath

	Whole unit	Top section	2x draws
↕	592	153	118
	404	352	320
	327	318	253



The lamp base takes up a lot of the top surface

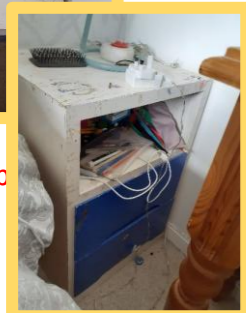

It is short in comparison to the bed so has to be offset in the room- reduced usability

The draws open on a traditional routed draw side- 20mm- running along a protruding wood bar on the frame. (simple)

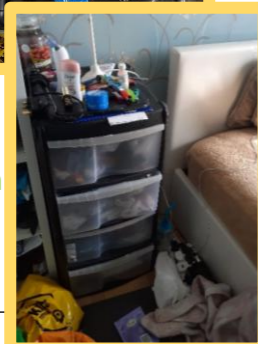
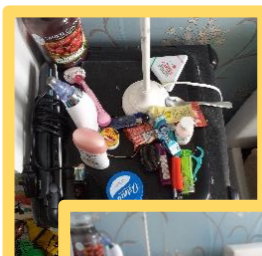

It is made of thin plastic - max. 5mm- making the unit weak and prone to bending and cracking in areas.

It is tall which means there is plenty of storage space for items such as clothes and has 4 separate draws allowing for better organisation of items

There is a shallow compartment with a fold up lid at the very top for more important documents

	Whole unit	Top section	4x draws
↕	820	36	172
	376	262	322
	382	314	358

This is a typical example of a bed-side table. It is a small unit with 2 compartments - one small open compartment near the top and another larger, closed one with a cupboard-style door. It has a blocky quadrilateral frame with curved edges, made of a natural wood timber that is coated in a simple varnish.

I cleared the top of the bed-side table so I could investigate the space efficiency of the surface top

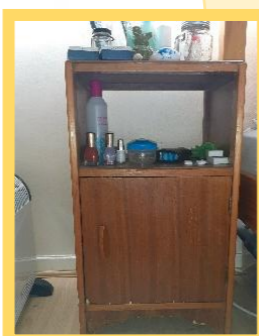

This is what I found for each object:

- ✓ eating gear (plate+mug) - the surface was large enough to comfortably fit all that is required for 1 person eating.
- ✓ laptop - at an angle the laptop fit with only the corners overhanging - still safe.
- ✓ textbooks - when open the textbook was too big to completely fit on the table but as you only read it it isn't that bad.
- ✓ School workbook - only one half fit well so it is only practical when the book is folded.
- ✓ 2 smaller notebooks - both were small enough to fully open with extra space for other things like a pencil case.

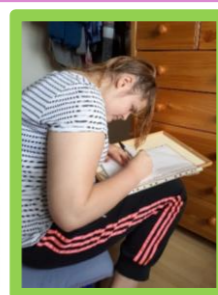

I asked my end user Sophie Sutherland to state positives and negatives and then her best and worst possible bedside table.

One good thing about a bed side table efficiency of the storage (big enough drawers) However a bad thing about it stains easily sometimes. The worst bedside tables you can have are small, unorganized and would stain easily. The best would be stylish and sturdy.

## Key elements

The overriding issues with these products:

- ↳ the surface tops don't have enough space.
- ↳ the height needs to be right - not too tall or too short (mid-thigh height).
- ↳ there isn't enough storage space / not enough range of storage types - draws, compartments...
- ↳ there isn't any storage intended / aimed at appliances and wires.
- ↳ the materials and mechanisms need to be appropriate for their use - not too heavy or stiff.

## Dimensions (in mm):

- ↕ height = 617
- ↔ length = 355
- ↗ width = 324
- top compartment:
  - ↕ 183
  - ↔ 322
  - ↗ 324
- bottom compartment:
  - ↕ 291
  - ↔ 322
  - ↗ 322

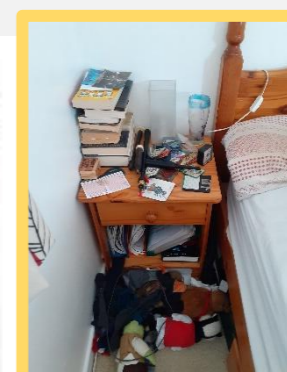

	Whole unit	draw	compartment
↕	538	84	267
	425	349	388
	366	318	366

Top overhang= 25

It doesn't offer enough types of storage for what is around- shelving, draws, dividers ect.

The base is fully lying on the floor without any form of raising such as legs- it couldn't sit well on many surfaces

It isn't large enough to keep all items around it safe and tidy

The draw is easily pulled out as it sits on a wheeled draw runner

It is too tall to use the surface top for anything other than displaying objects that need to be out- alarm clock

It includes 5 decently sized draws that are deep enough for keeping a large quantity of items- books and clothes

The draws are stiff and hard to open as they are on a wooden run not a metal mechanism

	Whole unit	5x draws
↕	900	122
	404	337
	347	306

Top overhang= 20

The top is being used to store / keep many things in a fairly messy manner  
 ↳ photoframe, pots, glasses...  
 ↳ this has left very little extra space for anything else or working

The bottom section offers a larger space to keep bigger items such as a bag as well as having a door so you can hide the objects - tangled wires.

The small handle is an odd shape and hard to grip.

The top section has an open back meaning things fall out the back often annoying + possibility of losing items.

The larger compartment has no form of splitter or shelf to break up the large space meaning it is difficult to utilise the space at the top

Wires get tangled and knotted

## Issues with technology

Plug sockets get surrounded by wires that are both being used and ones waiting to be plugged in

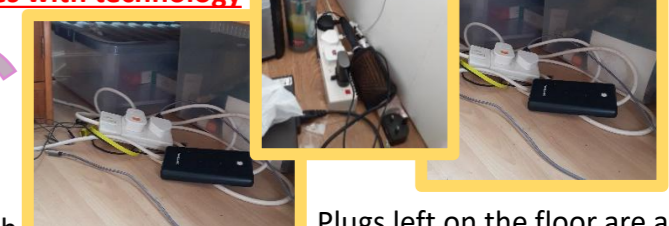

Plugs left on the floor are a tripping hazard and can cause injury

Often there isn't enough sockets for all appliances that require charging

**Next Step:** look at existing markets in this area to see what is already being manufactured and advertised.

My Response:  
 When designing my product I will bear this in mind and use suitable anthropometric data to make my product ergonomic and aesthetic. I will also ensure it has plenty of components to keep organised.

# Existing Products and design practices - second hand research

I asked my stakeholder James Sutherland to pick his favourite and least favourite piece from this page and give his reasoning.

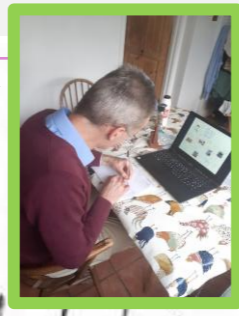

The pair of wooden bedside tables is very practical as there is a lot of storage space. However they don't look very English as they are plain & blocky.

Positives	Negatives
+ neutral, classic colours or varnished wood finishes.	- blocky and old-fashioned silhouette and design.
+ different options for working space or storage facilities.	- odd shapes and sizes that don't fit into different settings.
+ large enough components for different uses.	- the legs are flimsy and not practical.
+ any handles/components that may need to be comfortable and easy to use.	- no form of electrical intervention.
	- unattractive.

I like the look of the white unit with the brown legs (bottom right). I like the contrasting colour & slant of the legs. However, there is not a lot of storage space.

**My Response:**  
This shows that one stakeholder requirement is a good balance between aesthetics and practicality so I will make this a top priority.

The surface top is small limiting the use as it can only hold a standard reading book- not very practical.

It isn't very wide so when used perpendicular to the user the surface top would be off-centre and small- not practical for different scenarios.

It is rather short and the height can't be changed meaning it wouldn't be suitable to all possible users.

The bent shape of the metal frame allows the surface to rest on top of where someone is sat- a seat.

There is no form of long term storage- it is a very 'when necessary' product which would then have to be stored until required.

Its frame is made from brazed metal which is an extremely strong and durable structure.

The vertical handles look small which harsh edges implying that they may be tricky to grip making it harder to use especially for those with limited motion in their hands.

Rusty timber appearance which is likeable by many and can blend not a room with other wooden objects.

The mix of bold colours means it will not suit many rooms in a house unless pre-planned or that is a specific desired aesthetic someone subjectively wants.

The small curved feet add some feature to the blocky structure as well as being practical as it won't damage the floor it is placed on.

Offers plentiful closed storage so can be used to store lots of belongings which you wouldn't want to be on display for all to see.

Blocky aesthetic isn't pleasing as it is clunky and won't suit many rooms.

The dull design limits its usage as the large compartments are left as one with no form of separators meaning the mess will still be untidy just behind a door.

The legs seem planed to be thinner at the base but the whole leg seems to be rather thin and because it isn't that wide it may be quite fragile and prone to rocking.

The overhang gives it a larger usable work surface which could be used when writing or doing paperwork.

There is only one shallow draw which wouldn't provide much room for keeping a large range of objects.

The mix of colours make this piece more unique and quirky with a sleek, clean finish.

It only has two small draws as storage so although it has a large working surface it isn't as practical in being able to keep items organised and safe.

It has 2 surface areas of different heights which allows for desk space and a slimmer to keep and display belongings.

There is only one small handle which would be hard to grasp and manoeuvre the draws as they would be rather heavy to pull out.

The faded wood exterior is a nice delicate finish to the piece making it look rustic.

The draws are very shallow so would only fit smaller objects.

Black is a monochrome colour so it will be able to fit into many surroundings without looking out of place.

The square shape means it will be fairly wide so will stick out into a room considerably if put against a wall which may get in the way and waste precious space.

The long legs are limiting the space efficiency as they leave a large space not being used at all.

The mixture of finishes in this piece compliment each other and give a sleek appearance.

The draws are both the same size- not able to fit a range of objects.

The draw is larger meaning it has a big enough space for things other than small precious items such as clothes or organisers for jewellery.

It is very short- around knee height which means you wouldn't be able to use the surface for practical tasks-work.

The different compartments aren't all accessible from one side so there will have to be a large amount of movement and effort to use the draws.

The dynamic of the different shapes in a neat box adds interest to the aesthetic but allows a simple design to have some visual interest.

The bottom section is just one large open compartment which means it may be inefficient at saving space if the items stored there aren't that big.

Good visual for possible dimensions:  
Main block: 398.78 X 299.73 X 194.818 mm  
Draw: 80mm tall

It is a small storage to complete stand ratio meaning there is a mass of wasted space which could be used more wisely.

The 'handles are simple ergonomic holes that are cured to a comfortable hold for anyone to use easily.

**Next Step:** research the marketability of the multipurpose bed-side table and the potential for industry with its USPs by looking at how companies have advertised their existing products.

# Market Potential & more stakeholder needs

To research 3 main furniture stores in the UK I went to their websites, found the bedroom section and filtered from most popular or best rated to least in order to find the 'best' pieces in terms of the user ratings. This will hopefully give me a narrower insight into what the larger populations want in products and to see if my aim for a product would be desired in retail.



<https://www.ikea.com/gb/en/p/malm-chest-of-2-drawers-grey-stained-50454908/>

Product details: Malm chest of 2 drawers, grey stained. Features include smooth running drawers with pull-out stop and real wood veneer.

<https://www.ikea.com/gb/en/p/brimnes-chest-of-3-drawers-white-frosted-glass-00392041/>

Product details: Brimnes chest of 3 drawers, white frosted glass. Features include safety fitting and smooth running drawers with pull-out stop.



Designer: K Hagberg/M Hagberg



<https://www.wayfair.co.uk/furniture/pdp/17-stories-1-drawer-bedside-table-ayz2331.html?piid=36072169>

Description: 1 Drawer Bedside Table, mounted on the wall, wood construction, white finish.

<https://www.wayfair.co.uk/furniture/pdp/zipcode-design-audrina-2-drawer-bedside-table-wldh3016.html?piid=19298138>

Description: Zipcode Design Audrina 2-drawer bedside table, wood composite, minimalist design.

<https://www.wayfair.co.uk/furniture/pdp/zipcode-design-audrina-2-drawer-bedside-table-wldh3016.html?piid=19298138>

Description: Zipcode Design Audrina 2-drawer bedside table, wood composite, minimalist design.



<https://www.johnlewis.com/john-lewis-partners-grayson-small-storage-side-table/dark/p2469530>

Product description: Grayson small storage side table, dark wood, functional design.

<https://www.johnlewis.com/ercol-for-john-lewis-shalstone-bedside-table/p1872597>

Product description: Ercol for John Lewis Shalstone bedside table, solid oak, mid-century style.

<https://www.johnlewis.com/ercol-for-john-lewis-shalstone-bedside-table/p1872597>

Product description: Ercol for John Lewis Shalstone bedside table, solid oak, mid-century style.

**Key elements:** After looking into these three different furniture stores I am going to compile the key features and admirable traits that have been deigned and advertised as the USPs the shops portray will be the parts that the target audience will desire and want in a piece for them.



Handwritten notes listing key elements: neutral colours, easy to build, wooden, drawers, shelves, mounted, glass, free-standing, adjustable, doors, durable, functional, characteristics, materials, features.

Sophie Sutherland, one of my end users chose 5 key elements from the group above that she considers most important when searching for a piece of furniture.

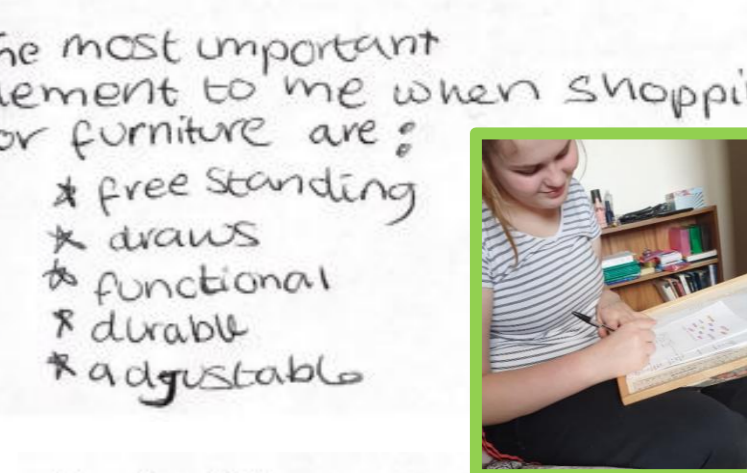

Handwritten notes: The most important element to me when shopping for furniture are: free standing, drawers, functional, durable, adjustable.

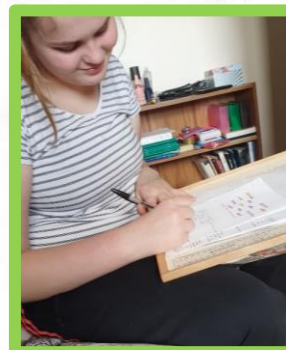

**Marketability:** once I have designed a product meeting the design brief I reckon stores like Ikea and wayfair would invest and produce them on a large scale because I aim to incorporate the values and requirements of stakeholders at every level. For John Lewis I may have to tweak it as it is a more expensive, bespoke-style store.

**Next Step:** Gather an understanding from the target audience of key features to include and the overall desires from the product.

To possibly find out more about these larger companies and mass manufacture I devised an email to send to the designers from these three main furniture companies in the UK.

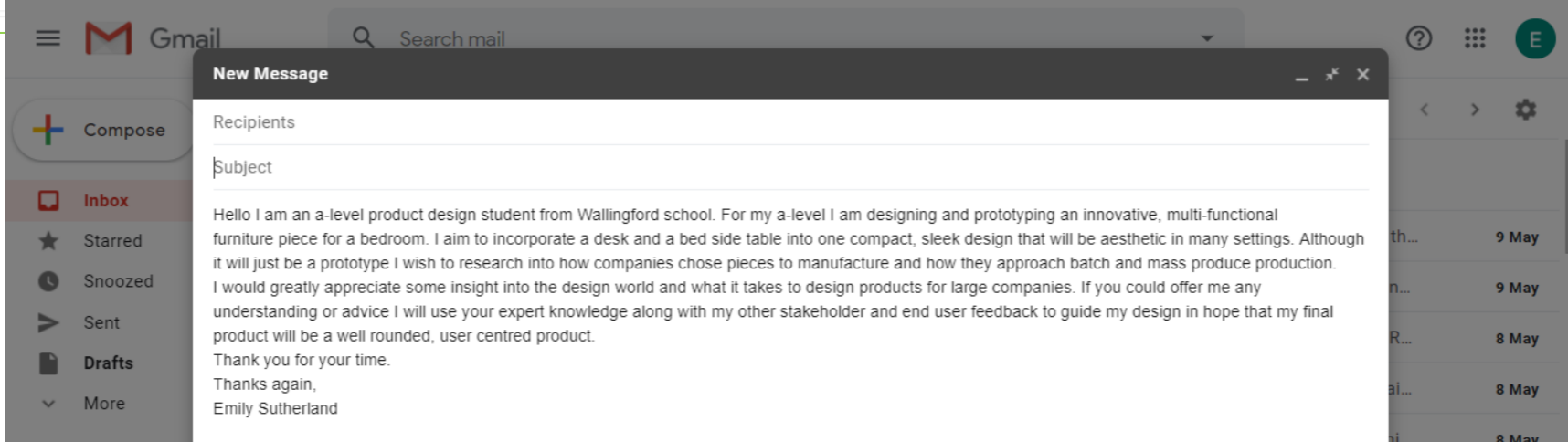

New Message: Hello I am an a-level product design student from Wallingford school. For my a-level I am designing and prototyping an innovative, multi-functional furniture piece for a bedroom. I aim to incorporate a desk and a bed side table into one compact, sleek design that will be aesthetic in many settings. Although it will just be a prototype I wish to research into how companies chose pieces to manufacture and how they approach batch and mass produce production. I would greatly appreciate some insight into the design world and what it takes to design products for large companies. If you could offer me any understanding or advice I will use your expert knowledge along with my other stakeholder and end user feedback to guide my design in hope that my final product will be a well rounded, user centred product. Thank you for your time. Thanks again, Emily Sutherland

# User and stakeholder needs and wants

Name: Charlotte Grove

1. Do you have a bedside table in your bedroom? Yes
2. Do you have a desk in your room? No
3. How many individual plug sockets do you use around your room? 5
4. What is the biggest difficulty when storing appliances and gadgets? Not enough storage
5. What type of storage do you prefer? (draws, baskets, shelving?) Drawers
6. What is your preferred furniture finishing? Paint? wood? Natural glass? Wood
7. If you were going to purchase a painted piece for your bedroom what colour would you prefer? Teak
8. What features would you like to see in a multifunctional storage type unit? Space for books, shoes, display shelves & baskets for storage
9. Do you like furniture to have the exterior presentation of being made out of one chosen material or a mix? If mix what combination? (metal, wood, glass, patterned) Combination - more modern
10. What multi-functional piece of furniture would you find useful for your bedroom? Over bed storage



Name: Sophie Sutherland

1. Do you have a bedside table in your bedroom? Yes
2. Do you have a desk in your room? Yes
3. How many individual plug sockets do you use around your room? Four
4. What is the biggest difficulty when storing appliances and gadgets? Making sure it fits without damaging the object
5. What type of storage do you prefer? (draws, baskets, shelving?) A mixture of open and closed spaces.
6. What is your preferred furniture finishing? Paint? wood? Natural glass? I like white paint + glass it's stylish but not in a bedroom.
7. If you were going to purchase a painted piece for your bedroom what colour would you prefer? Painted white however it depends what colour the room is.
8. What features would you like to see in a multifunctional storage type unit? Desk with drawers, a stationary holder, a storage compartment.
9. Do you like furniture to have the exterior presentation of being made out of one chosen material or a mix? If mix what combination? (metal, wood, glass, patterned) I like a mix of varnished wood and painted woods
10. What multi-functional piece of furniture would you find useful for your bedroom? A combination of a bookshelf, a chest of drawers and a mirror.

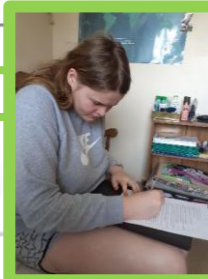

I devised 10 key questions to ask a range of stakeholders and users in order to collect opinions into what they desire in my final product. I set it out in a word document as seen here

## Questions:

1. Do you have a bedside table in your bedroom?
2. Do you have a desk in your room?
3. How many individual plug sockets do you use around your room?
4. What is the biggest difficulty when storing appliances and gadgets?
5. What type of storage do you prefer? (draws, baskets, shelving?)
6. What is your preferred furniture finishing? Paint? wood? Natural glass?
7. If you were going to purchase a painted piece for your bedroom what colour would you prefer?
8. What features would you like to see in a multifunctional storage type unit?
9. Do you like furniture to have the exterior presentation of being made out of one chosen material or a mix? If mix what combo? (metal, wood, glass, patterned)
10. What multi-functional piece of furniture would you find useful for your bedroom?

## Analysis of answers:

1. **All** have a bedside table.  
Shows that my product has a large market as most people utilise bed side tables. Because of this, I will make this a focus so that it can defiantly sit beside most bed types.
2. **1/4** have a desk in their room.  
I will incorporate a large surface area which can be used as a desk as this is something a lot of people don't have in their bedroom making my product stand apart from others and more efficient for users.
3. There was an average of **4 plug sockets** used in bedrooms.  
I may include sockets in my product as an increase in technology means more may be desired.
4. Issues were: **not enough space**, keeping them **safe** without damage and having them close to sockets for charging.  
People will benefit from my product as I will ensure there is a specific space for storing appliances safely. This shows the need for plugs being inbuilt in my product.
5. 2 people stated they want **shelves** whilst **draws** were also mentioned.  
My product will include a mix of open shelves and closed storage space.
6. The majority of the answers stated they desire a **wood finish** whilst white paint was also popular.  
The main body of my product will be a stained/varnished wood finish with a changeable top surface- could be painted.
7. All said **white** is the preferred colour of choice.  
Neutral colours such as white are popular giving a clean finish. Paint can be used on the top surface of my product to give it an individual finish to it- customisable option.
8. 'Open, shoe storage, book storage, display, baskets, lighting, stationary holder, draws'  
My product is going to be a combination of features including shelves, closed storage, lights and space for different objects.
9. Most like furniture made out of **multiple materials**.  
I will use different materials for the legs, the frame and the top.
10. Storage unit with: space for clothes, bookshelf, draws, mirror.  
Letting end users discuss what they would design highlights the features they really care about. I will ensure to incorporate spaces for clothes and shoes as these were most talked about.

- Name: Joe Usbet
1. Do you have a bedside table in your bedroom? Yes
  2. Do you have a desk in your room? no
  3. How many individual plug sockets do you use around your room? all
  4. What is the biggest difficulty when storing appliances and gadgets? not enough space
  5. What type of storage do you prefer? (draws, baskets, shelving?) (shelving)
  6. What is your preferred furniture finishing? Paint? wood? Natural glass? depends on the room
  7. If you were going to purchase a painted piece for your bedroom what colour would you prefer? White
  8. What features would you like to see in a multifunctional storage type unit? open, with draws, and maybe shoe space plus lighting maybe to make sure you can see.
  9. Do you like furniture to have the exterior presentation of being made out of one chosen material or a mix? If mix what combination? (metal, wood, glass, patterned) depending what it was, but neat looking
  10. What multi-functional piece of furniture would you find useful for your bedroom? something big with lots of space for maybe a mirror, like a make up stand, plus space for books, shoes, cloths.

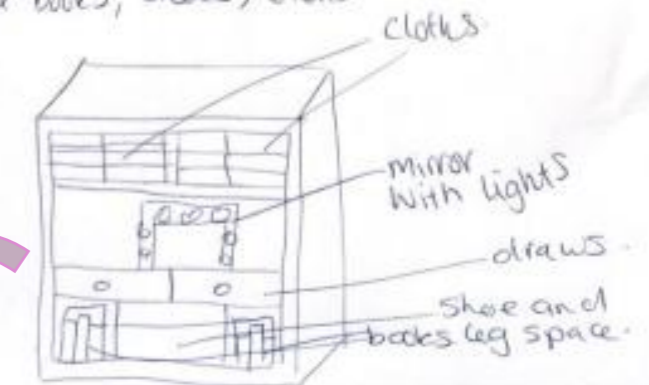

This is a full wall furniture piece but I will try to include different elements of it in a piece that can fit beside a bed and be used as a desk. I will try to include clothes, shoe and book storage as well as lights.

Name: James Sutherland

1. Do you have a bedside table in your bedroom? Yes
2. Do you have a desk in your room? NO
3. How many individual plug sockets do you use around your room? 2
4. What is the biggest difficulty when storing appliances and gadgets? KEEPING THEM SAFE, CLOSE TO THE SOCKETS WHEN CHARGING
5. What type of storage do you prefer? (draws, baskets, shelving?) SHELVING
6. What is your preferred furniture finishing? Paint? wood? Natural glass? WOOD
7. If you were going to purchase a painted piece for your bedroom what colour would you prefer? WHITE
8. What features would you like to see in a multifunctional storage type unit? VARIEITY OF SIZE OF SPACES. FLEXIBILITY
9. Do you like furniture to have the exterior presentation of being made out of one chosen material or a mix? If mix what combination? (metal, wood, glass, patterned) SINGLE
10. What multi-functional piece of furniture would you find useful for your bedroom? OVERNIGHT STORAGE OF CLOTHES.

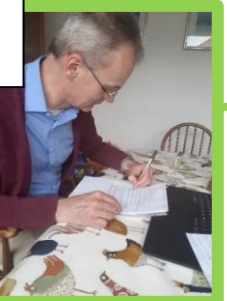

**Next Step:** video interview a different stakeholder and conclude my finding for user wants and needs. Develop a non-technical specification.

# Non-technical Specification

This is Callan Wintle's interview response to the devised questions.



## Final conclusions from stakeholder research:

- Everyone I asked had a bedside table whilst less than half has a desk. This means that there is a large target audience for a product that can be used as a desk and even better if the standard bed side table can be adapted to include one as this reduces the need to buy multiple pieces of furniture which could put people off.
- People use an average of 4 individual plug sockets in their room. This means that they are commonly used for different uses and consequently will be desired to have them in one space, close together rather than having to have different sockets at random places around the room.
- Issues often arise when storing appliances where there is not enough space and they can't be stored safely. This means that a my product would have to offer a spacious dedicated area for technology that may have an organisation system such as splitters to separate the space for separate objects in order to keep them tidy, organised and to ensure their safety with reduced chance of damage.
- The majority of my stakeholders would like to see shelving, draws and open compartment in a piece of storage furniture with a stylish wooden or white painted finish. This means that practicality has to be a main priority whilst aesthetics and style should be in tune with trending fashions of plain, sleek finishes.

## Takeaway from the interview:

- He has a desk with a bedside table underneath.
- He has **2 sockets** with a 4 way splitter.
- Leaves his phone on his desk when charging.
- He prefers shelving- 'easier to sort through stuff when you can visually see it'.
- He likes **drawers** for things that aren't 'visually appealing'.
- Likes varnished wood finish.
- For a multi-storage unit:
  - **4 way splitter with 2 USB and a USB micro output**
  - **Lights**
  - **Shelving and draws with a desk**
  - **Wooden- oak?**

Overall, from a stakeholder who is knowledgeable in the area of technology, he highlighted the want for the use electrical components such as lights and charging sources with possibilities for different power outlets to be used.



**Next Step:** look at the materials you could use and see how that could be possible and understand the requirements that come with different materials.

## Non-technical specification:

Based off my research into stakeholder wants and needs over the last few pages, I will create a multi-functional product for a bedroom that **MUST**:

- ❖ Be space efficient
  - **A maximum of 700x 450x 800mm**
  - So that it can fit in smaller spaces making it efficient in most rooms, including smaller room sizes.
- ❖ Have a range of storage space
  - Including shelving and some closed space for storage of different items so people of different ages can make use of the product.
- ❖ Have a good quality of finish
  - **Wood finish (varnish) with painted highlights**
  - So that users can confidently use the product without fear of easy damage and to allow it to be easily cleaned whilst keeping high quality aesthetics.
- ❖ Allow for technology to be used in conjunction with it with ease
  - Including power sources- sockets and a means of safely storing appliances so users can organise and efficiently store and charge their most used items.
- ❖ Offer both visual and organised storage space for safe keeps
  - ❖ So that most belongings, no matter the size or value may be safely stored without fear or loss or damage.

# Possible Materials

Example	Properties/ Characteristics	Uses	Example	Properties/ Characteristics	Uses
<b>Hard wood</b>  <b>Oak</b>  <b>Teak</b>	Strong, durable and hard, though still easy to work with. It is rather heavy but has good weather resistance. It is attractive, light brown and open grained.	High quality furniture, veneers & flooring.	<b>Ferrous metal</b> <b>Mild steel</b> <b>Cast iron</b>	Tough, ductile and malleable yet still easy to machine. It has high tensile strength and it's inexpensive but it is prone to corrosion.	Nuts, bolts & car bodies.
	Hard, tough and durable with high oil content making it moisture resistant. It is golden brown with a straight grain.	Outdoor furniture, lab benches & boats.		Hard exterior that deals well under compression. It is resistant to wear and rust but is rather brittle so can't be bent or forged.	Manhole covers & kitchen pots.
<b>Soft wood</b> <b>Pine</b> <b>Spruce</b>	Lightweight but reasonably strong and easy to work with. It is a pale red- brown with a distinctively straight grain with plenty of knots. It is rather inexpensive.	DIY, construction & door frames.	<b>Non-ferrous metal</b> <b>Aluminium</b> <b>Copper</b>	Lightweight and ductile. It is resistant to corrosion and is a good conductor of heat and electricity.	Aircraft bodies, saucepans & food wrappers.
	Good strength to weight ratio with good levels of hardness. It has a straight grain but is resistant to splitting and is a yellow- white colour.	Indoor furniture & construction.		Ductile, malleable, tough, relatively soft and corrosion resistant. It is a great conductor of heat and electricity.	Electric wires & water pipes.
<b>Manufactured board</b> <b>Plywood</b> <b>MDF</b>	Layers of veneer glued at 90 degrees that is easily machined with great strength in all directions that is water and heat resistant with no grain weakness.	Construction, furniture & boat building.	<b>Alloys</b> <b>Brass</b> <b>Stainless steel</b>	A combination of copper and zinc. It is malleable and hard with low friction and melting point meaning it can be easily cast.	Locks, door handles & plumbing accessories.
	Compressed wood fibres (usually put to waste), mixed with a bonding agent and flattened into smooth sheets that are easy to work with and apply finishings. It is denser than other boards.	Furniture, models & in flat pack pieces.		A mix of steel, carbon, chromium and tungsten. It's tough, strong, hard and resistant to corrosion but also, hard to machine.	Cutlery & medical instruments.

## Solid Wood Metal

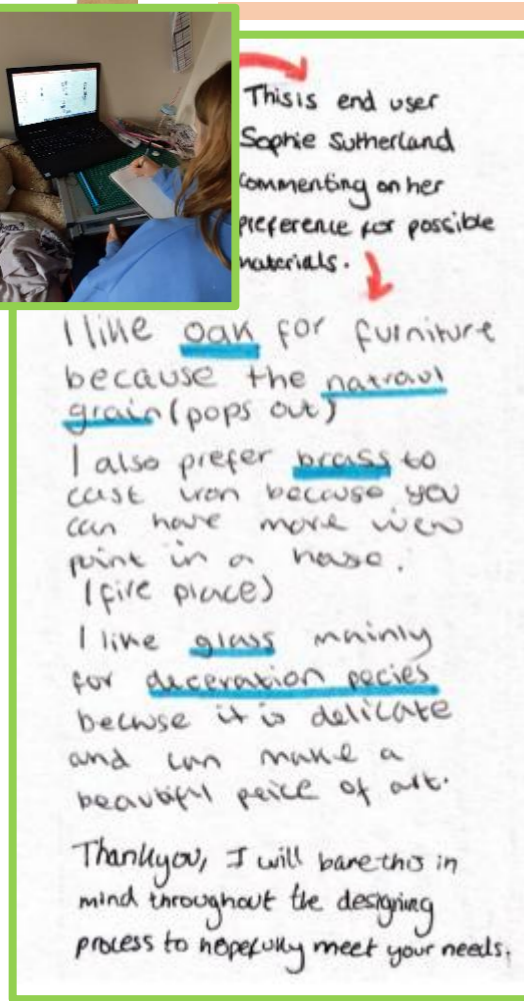

This is end user Sophie Sutherland commenting on her preference for possible materials.

I like oak for furniture because the natural grain (pops out)

I also prefer brass to cast iron because you can have more view point in a house. (fire place)

I like glass mainly for decoration pieces because it is delicate and can make a beautiful piece of art.

Thankyou, I will bare this in mind throughout the designing process to hopefully meet your needs.



Using glass in furniture can be risky as it is a more vulnerable material than most other resistant materials such as wood and metal however, it is being used increasingly more in modern furniture due to its sleek look.

I researched into this using *online sources* for 'Using glass in furniture' to explore an in depth evaluation of the material and its use to find:

- ✓ Aesthetics- elegant and sophisticated.
- ✓ It enhances the look of materials it is paired with (wood, marble, etc...).
- ✓ Its transparency doesn't block views which creates a better illusion of visible empty space as the light is distributed evenly.
- ❑ High maintenance to keep it clean with regular wiping down needed to keep the material clean and in good condition.
- ❑ It is fragile meaning a care has to be taken into preventing scratching and chipping. In some cases this will involve exterior furnishing such as place mats to avoid any breakages.
- ❑ It is an expensive material, especially when sourcing tempered glass which has been thermally and chemically strengthened to make it better for use in furniture.

<https://www.franceshunt.co.uk/news/2015/03/pros-and-cons-of-glass-furniture/>

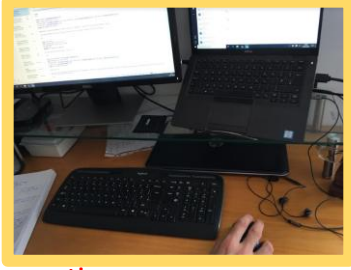
### Glass

### Other composites

Both of these materials require moulds for different components meaning they are extremely expensive processes to use in smaller scale production. This is because each mould is specific to a component, making the products uniform, but also making it complex, especially is the product itself is rather complicated.

Plastics come in 2 forms: thermoplastics and thermo- setting plastics. These are both used in furniture production however, recently a push has been set into using more thermoplastics because these are the one that can be moulded, set, melted and remoulded making them so much better for the environment. Plastic furniture is durable and easy to clean but it can also be brittle and easily scratched and snapped.

### Plastics

<https://www.youtube.com/watch?v=ioZGAIIRlo>



Concrete is a material that is being used at increasing rates in today's designing world. It is a composite of materials such as rocks, mixed into a paste, allowing it to be moulded. This means it is easily shaped into uniform pieces using simple moulds (better for use in industry) and it is a versatile and malleable material to work with.

Concrete

However, it is a rather blocky material with harsh edges and it can be incredibly heavy and hard to manoeuvre.

The Plastic Whale Organisation in Amsterdam is an organisation set up to collect waste plastic from the canals in order to clean the waterways and also collect plastics to create new, stylish furniture. It is backed by some major companies for its moral standing.



[https://www.google.com/search?q=using+concrete+in+furniture&rlz=1C1CHBF\\_enGBGB862GB862&oq=using+concrete+in+furniture&aqs=chrome..69i57.8482j0j15&sourceid=chrome&ie=UTF-8#kpvalbx=cin8XrC-Mc2e1fAPvbmi8AU25](https://www.google.com/search?q=using+concrete+in+furniture&rlz=1C1CHBF_enGBGB862GB862&oq=using+concrete+in+furniture&aqs=chrome..69i57.8482j0j15&sourceid=chrome&ie=UTF-8#kpvalbx=cin8XrC-Mc2e1fAPvbmi8AU25)

**Next Step:** research into how I could use a fixing/ hinge mechanism in my piece for a fold out extra surface.

# Technical requirements- table Fixings & Weight Distribution

To get an idea of possible different fixings I could use to add extra features for example a pull out/ fold out additional surface top, I analysed products with some of these features in use so I could assess how I could use them in my piece.

## Explorations

At the back there is a fold out piece that opens, allowing the surface to sit perfectly at 35 degrees to any 90 degree corner.

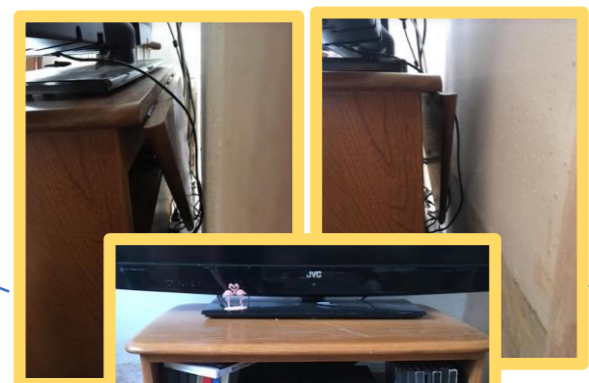

TV stand

The fold out back is sat on a simple hinge system that can be raised at any point but just requires someone to pull out a wooden block hidden in the open section below the section.



This makes it easier for people to use as it isn't complicated or requiring a sophisticated user.

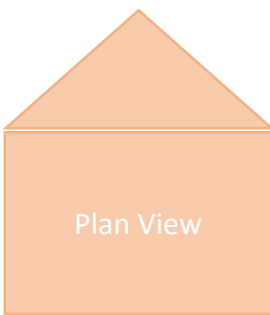

Plan View

When folded down, the extra piece of wood hides the open compartment, making it only open on one side, worsening the usage to just shelving.

The surface area is dramatically increased extending backwards. The only issue is it makes the piece an odd shape that can only be used in a corner rather than anywhere in a room.

This is stronger and more reliable for shelving than plain basic hinges.

### Folding shelf support brackets



These are a replacement for brackets that support themselves, meaning no exterior effort is required other than the initial notion of moving the extra section.

The only time it becomes unstable is when a heavy load is placed near one of the outer corners of the desk as the weight distribution is very uneven.

It only works when the desk is rested upwards though, due to the bracket placement.

This means that if I were to use a similar method, I would have to consider it and design it into the product.

It works on a basic hinge system that is supported by 2 support struts - one strut for each side.

These slide in and out and allow the full, large table to be strong everywhere.

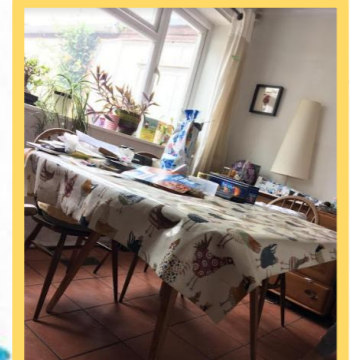

The table can be quite creaky when put under weight near the corners so it would be more structurally sound when scaled down.



The system under the table is rather bulky and industrial meaning it may not be so good for smaller products.

Simple and basic but requires a backup support system if used parallel to the floor.

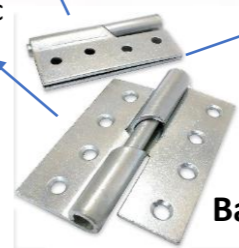

Basic Hinges

It comes in a variety of stock sizes with varying strengths for different uses.

The support poles are heavy and can be tricky to move, making it less usable for a large audience.



This large table is made up of 3 sections:  
 • the stationary middle section that supports everything else.  
 • 2 x side sections that fold down, leaving a slim rectangular table.  
 • This works to make the table versatile and quirky.

The 2 side sections fold at 90°, making the table small and compact - space efficient.

The system underneath is fully manual with no automatic features.

This means that effort is required but it's also simple and can't fail.

Thankyou for your advise. I will aim to use a bracketed system wherever possible as this seems easiest but I will explore different possibilities through my designs.

**"I think each of these fixings were very suitable for the circumstances they are found in. In my opinion the best would be in the writing desk in the top right because the pull mechanism works in a system that only requires one movement from the user- the pulling down of the desk. This is easier for the user and doesn't require any added faffing around. For a smaller product like yours it would be best for you to find a mixture of hinges and support or a suitable bracket that would work well."**

I asked stakeholder **James Sutherland** to comment on which fixings he thought worked best and were most suitable. This is what he said:

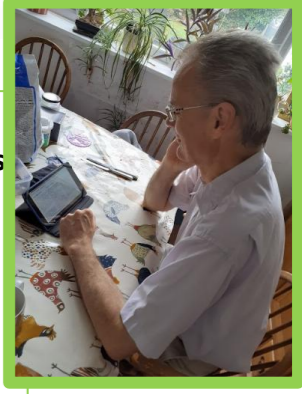

**Next Step:** Investigate in more detail and create an overview of the specific materials, joints and fixings that I am planning on using in the final product.

The two way support system is efficient and works well for desks as it can support enough weight.

It works on a top bracket that locks in place so that it doesn't go further than 90° from the draws.

Alongside the bracket, there are 2 support beams underneath to provide further support.

The fold down part is lightweight and on a smooth system that doesn't jolt at any point - easy for everyone.

The support beams work on a system so that as you pull the desk down, they come out in line, meaning no further effort is needed to make it fully usable. efficient.

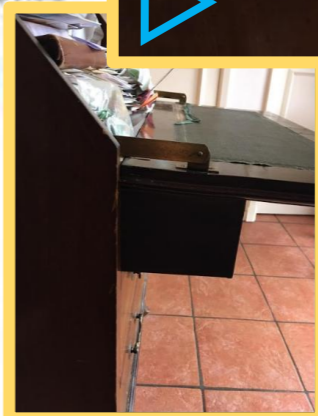

The top compartment is angled and the 'lid' can be folded down to produce a desk.

# Possibilities at an Industrial Scale

Examples of different components / elements that would need to be tweaked in order to be made industrially.

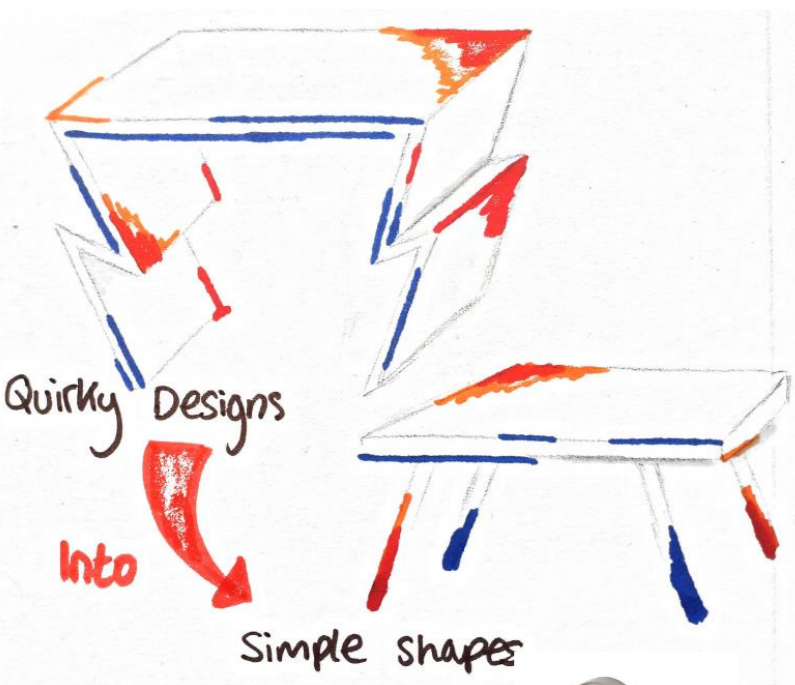
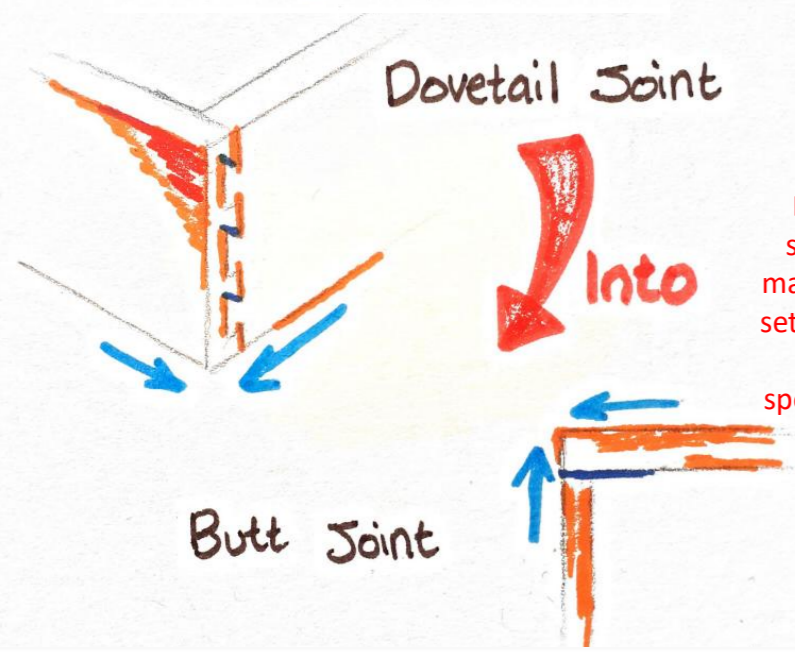

The use of standard components such as door handles, rather than intricate unique / specialist ones.



I decided to research into the possibility of industrial manufacturing for products like my own.

**CNC routers** are computer numerical controlled routers used for cutting a range of materials including glass, woods, some metals, plastics and composites. They can be set up with specific measurements so that material can be repeatedly produced to the same shapes and sizes.

Due to the high sophistication of machines, the initial set up costs are high and require specialists to design and make the complicated machines.

## Machinery

**Production lines** are used using automated machines and components such as jigs and fixtures. This allows swift manufacturing of identical products.

- ✓ Flexible
- ✓ High speed and production rates
- ✓ Fully automatic
- ✓ Optimises output
- ✓ comprehensive analysis enabled by transparent presentation of data from machines
- ✓ It can be adapted to not only mass production, but also smaller scales

**Cobots** are machines that work besides humans to enhance production teams capabilities and technical levels whilst not replacing human input. This creates a balance of workforces, allowing optimised production rates.

**Injection moulding** is used wherever possible at industrial levels as it involves creating one mould for detailed components that material can be blasted into at high temperature or pressure, to rapidly create the perfect shape, ready for the next load of material.

Unique barcodes on each component allows system operators to communicate information efficiently.

## <https://www.youtube.com/watch?v=KUKI-c5uWbM> Networks Production

A central control system operates to monitor information flow between components, allowing the machines to work well as a large system.

Smart machinery with individual controlled production that is resource efficient in tailoring to meet customer needs.



Production at an industrial scale

Each machine component is individual and created on a virtual world as a digital element before it is made in order to perfect the machines and maximise their usage.

For the designer this means that thorough thought has to go into how to make it easy to assemble using **simple construction techniques** so that the majority will be able to build it. Also, great consideration will have to go into the instructions so that it appeals to a wider audience.

It saves space in delivery vehicles, making it more eco friendly as less vehicles are needed and it saves time in manufacturing.

From this it is evident that a product like my own would be suitable and feasible for mass production on an industrial scale if it is designed as such. This can be seen in the simplistic adaptations to change a unique piece into something that can be produced on a huge scale. This is also becoming easier due to the ever advancing technology used in manufacturing.

**Screws, nuts and bolts** are often used in furniture pieces because they are simple and can be achieved quickly, especially by machine if not flat packed.

## Joints

**Laminated woods** are also used. These are large sheets that have the exterior appearance of wood grain but is made of a composite wood mix in the centre.

The only downside is that there has to be a further process of coating the material.

**MDF** is widely used as it uses a lot of waste material (more sustainable) and it is easy to work with whilst having great strength.

## Materials

Only simple wood joints are used such as **butt joints** without any awkward angles for machines to manoeuvre.

**Basic components** are used to limit the complexity and maximise the efficiency and production output rates.

To keep the costs reduced for the individual product, large scale manufacture often uses cheaper material that is easily workable yet still durable.

Another consideration for manufacturing is the **packaging**. When flat packed, the furniture is easier to safely package out of harms way but it is much harder to package larger pre built pieces so that they won't get damaged on the journey. It also always comes with a cost- both economic and environmental.

**Pre assembled** furniture is less common but it does offer ease for the end user as no effort is required into building and there isn't room for user mistake meaning the product is more likely to be reliable and well assembled for long term use.

## Packaging/ assembly

The most common type of furniture delivery is that that comes as a **flat pack**. These come with all the component and instructions to help end users to build it themselves.

**Next Step:** Sketch out my first design possibilities to start visualising the aesthetics and features I wish to include for my target audience.

# Initial Designs

**Different shape variations**

- bending plywood would be easiest
- meaning it would be painted finish.
- curved corners
  - more modern look ✓
  - less damagable ✓
  - allows things to fall off more easily. ✗
- limited storage variety.
  - only 2 compartments. ✗
- 2 support poles needed.
  - Maintained strength ✓
  - adds to aesthetic ✓
  - adds weight ✗
  - more complex ✗

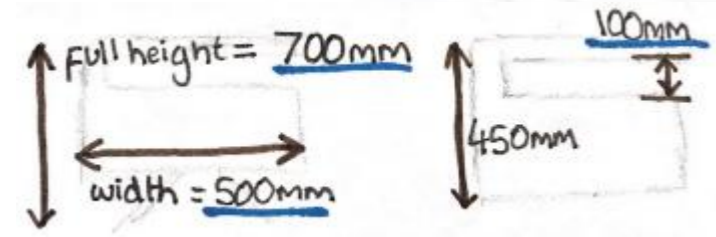

continuous support pole.
 

- strength ✓
- continuing aesthetic ✓

 2 open sections of different heights.
 

- more variety ✓
- better functionality ✓
- limits the space for other components underneath. ✗

 the metal feet would have to have a protector at the bottom so it doesn't damage floors.

The support pole allows the top to be used for storage or working - it has good strength.

**Key Components**

- Open Compartments/ Shelving**: decorative, popular and aesthetic - easily applied.
- Baskets**: tidy, can be used in open areas to organise, such as the lower compartments in these designs.
- Draws**: space efficient, different sizes can be used (seen across all my designs on this page).
- Closed compartment (doors)**: offers an alternative/extra to the baskets so could be used in the base of these designs.
- Simple butt joints**: for speed and ease.
- I would use mild steel.** It is easy, durable and strong enough.

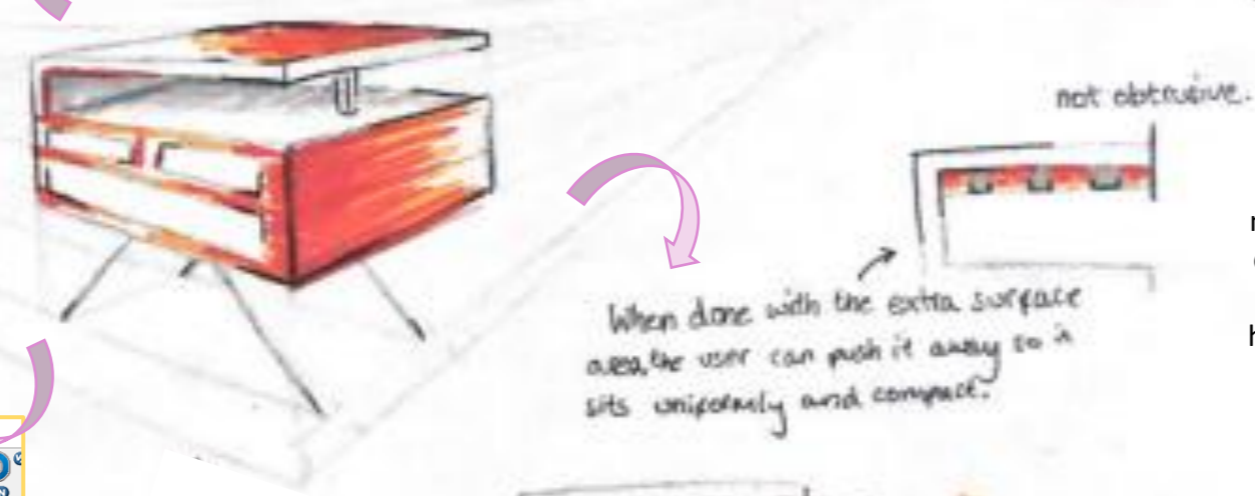

I made this simple model representing one of the design variations so that the end users have something feasible to interact with whilst giving feedback.

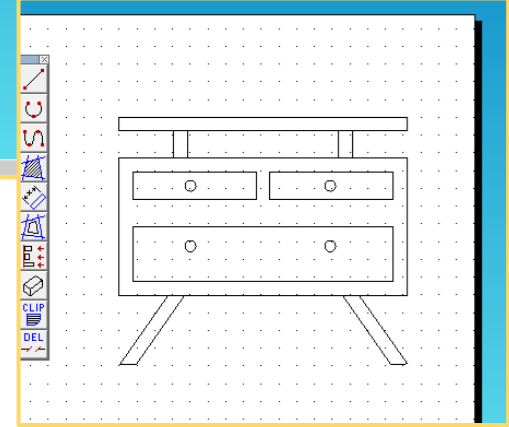
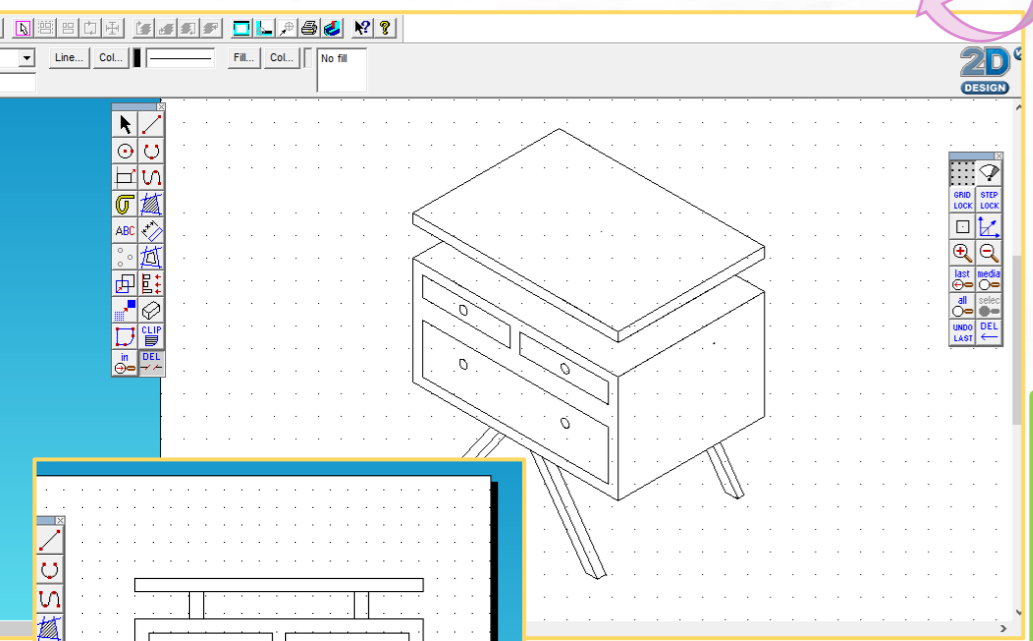

**Next Step:** continue designing perhaps focussing on a different element such as a metal framework to gather a larger variety of ideas.

This is a short clip of Sophie Sutherland giving feedback on these designs whilst analysing the model.



"I like some of these designs because the curves are something different that I haven't seen before. The only thing I would say is most of these designs like in the model are rather open which means things would easily fall off especially if you keep a lot of belongings."

"My favourite is the drawing in the middle which has a larger mix of parts which I assume would have different draws. I like this because it still has the same style as the ones with more curves, but it could be more rounded at the top if need be. I was just wondering if you could possibly put some system where if there is draws - especially deeper ones, there could be lights rimming the draw or inside it so that it is easier to see into them even when doing so during the evenings when in your bedroom."

Oh great, I will consider using curves and a range of aesthetic features in my final product. I would really like to incorporate more than just open spaces such as shelving as I know this is desired by many stakeholders and end users for products.

I would adapt the favourite design into something like this →

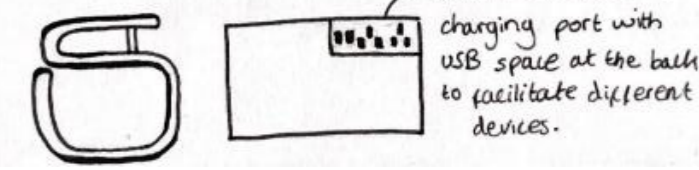



# Initial Designs

# Glass

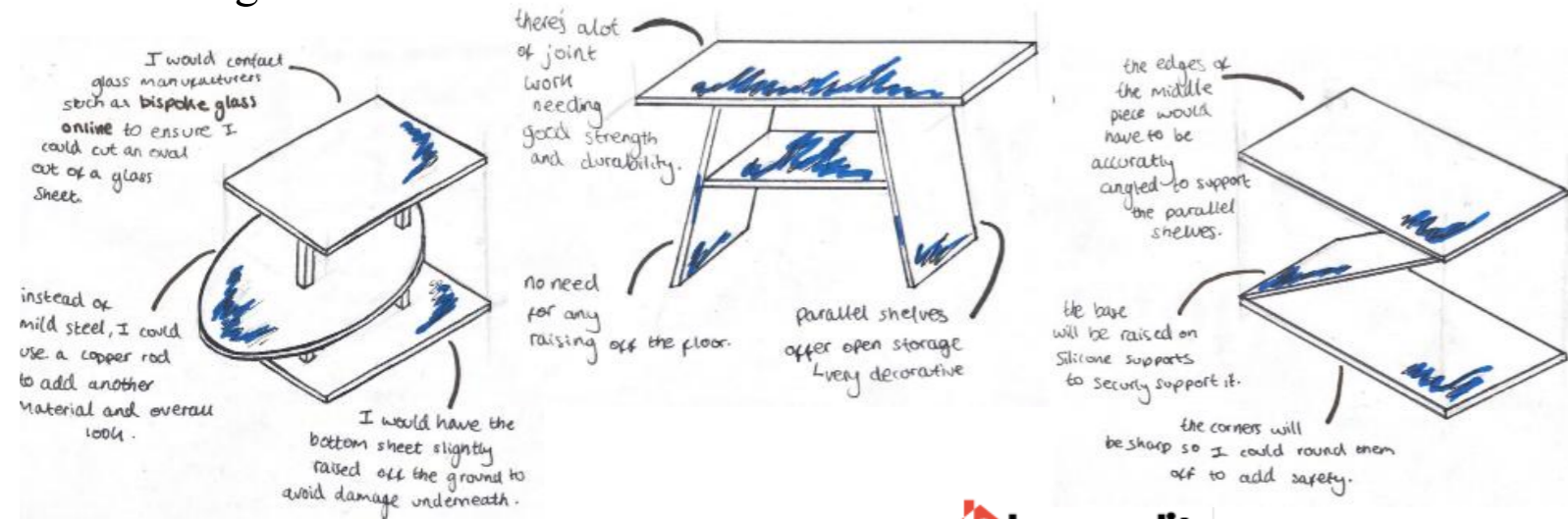

GREAT OUTDOOR IDEAS S1 E84  
How to Make Furniture From Concrete | Outdoor | Great Home Ideas

[https://www.youtube.com/watch?v=LTER\\_Lin1kg](https://www.youtube.com/watch?v=LTER_Lin1kg)

# Concrete

1. Mark out the main view of a template for your product. (**form ply** is a material that can easily be shaped into a mould and **aluminium** is easily wrapped around the sides, attached with **screws and silicone** to create the side of the mould.)
2. A concrete mix is then poured into the lubricated mould topped with a metal crossbar reinforcement for strength.
3. Once flattened the concrete is left to dry for a number of days.
4. When removed no further treatment is necessary and if components are large enough, they will safely balance on top of each other.

## Outstanding Glass Furniture Designs For Contemporary Interiors



<https://www.homedit.com/glass-furniture/>

**Homedit** focus on glass furniture due to their passion for its durability, easy manufacture and transparency.

**Giovanni Tommaso Garattoni** designed the 'naked' armchair in 2002  
↳ adjustable leather/glass duo seat.  
↳ weighs **67kg**. Made out of **20mm** thick glass - strong + durable.

For furniture, the strongest option for glass would be toughened laminated glass sheets in either **21.5mm** or **24.5mm** thick.



**Toughened Glass**  
Including Optiwhite, Tinted, Heat Soaked, Heat Strengthened or just Un-Toughened Annealed. All supplied to BS EN12150 & BS EN12600 Standards. Ideal for Shower Glass, Glass Partitions, Table Tops, Splash Backs and low height Balustrading.

**Laminated Glass**  
Ranging from 6.4 mm to 12.8 mm, Laminated Glass is ideal for Shop Fronts, upgraded window glass, Security Glazing and Garden / Lean To Roof glazing.

**Custom Shapes and Sizes**  
Bespoke Glass will cut Toughened glass to a range of bespoke shapes and sizes as required?

**Toughened Laminated Glass**  
Ranging from 9.5 mm up to 21.5 & 24.5 mm Double Laminate is ideal for Balustrades and glazing at height. With Triple Toughened Laminate of 33 & 39 mm being ideal for walk on glass & pond glazing. Just give us a call to discuss your requirements?

**Specialist Double & Triple Glazing**  
We specialise in providing combinations of the above in sealed units in a wide range of hard to find shapes and sizes including large oversized formats.

**Fireglass**  
We can also provide a range of fire glass to suite most requirements?

[https://bespokeglassonline.co.uk/?gclid=Cj0KCQjwkb8b7BRCaARIsAARRTL7NF6W2q5KNENMLU7KU-Uhsgz15t0fM-gVlyfWYBndbwoYJHcfywGAaAh5wEALw\\_wcB](https://bespokeglassonline.co.uk/?gclid=Cj0KCQjwkb8b7BRCaARIsAARRTL7NF6W2q5KNENMLU7KU-Uhsgz15t0fM-gVlyfWYBndbwoYJHcfywGAaAh5wEALw_wcB)

The glass designs seem sleek & modern, while the concrete seem bulky & heavy in comparison. Production of the concrete designs could be scaled up, which is good if they are intended for sale. You do get interesting shapes with the concrete.



**James Sutherland** end user commenting on his preference on these obscure material choices.

I agree that the glass and concrete are a great alternative material to use. Glass is better for aesthetics whereas, as stated the concrete will be better for an industrial scale which is better on the big scheme of things as one mould is used.

**Concrete Furniture**

- Industrial scales
- All modelling + moulding material can be recycled and reused.
- this makes the process better for the environment and more sustainable for long term production.
- anechoic chamber style
- When thinking of shapes for products made of concrete, the possibilities are endless due to the moulds.
- Because of this, I took inspiration from anechoic chambers (triangular) and other, more complicated shapes such as circles.
- Concrete designs can easily be made in 1 big mould, rather than small components - intricate designs, quicker and cheaper.
- the moulds would have to be sturdier and more permanent.
- perhaps fully metal so it is more durable and can withstand many uses.
- The setting process would have to be sped up.
- Hardening chambers could be used - applying heat in order to set the concrete much quicker.

Collection of some CAD designs possible for industrial moulds for concrete product manufacture.

**Next Step:** look into products that have different compartments that could be 'built up' out of different components.

Initial Designs

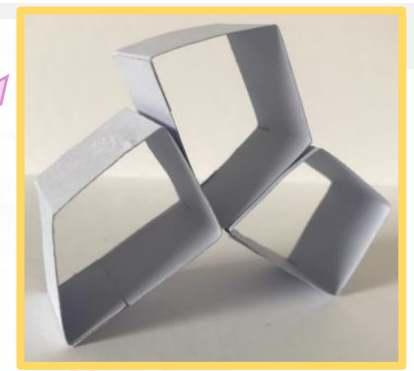
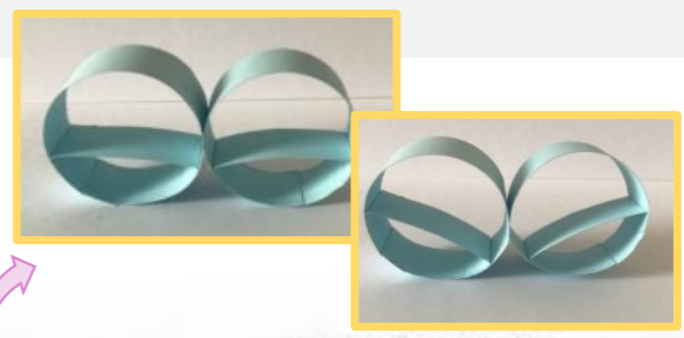
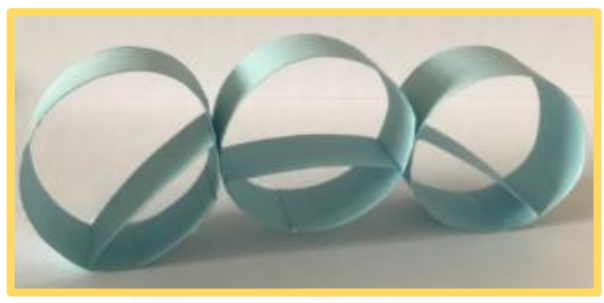

Shelf can be angled to create desired look.

Rounded makes it harder to store a large range of belongings.

good storage option when placed square on.

When placed with others, it is individual and eye pleasing.

Mosaic style finish

Simplistic box shape - boring and not appealing.

odd angles require strong fixings to secure them as certain pressure points are weakened.

display options are limited without thought into ways of securing the items in place.

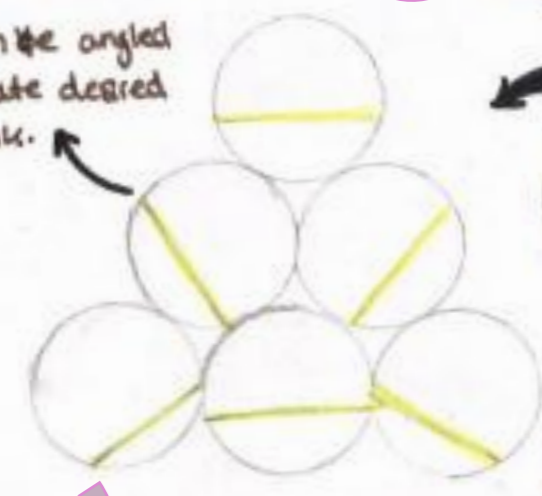

could have an option to get one with an extendable dash from this 'shelf'

has a flat 'shelf' in every component.

mass production using layered plywood

Painted finish means a range of options can be available.



Thankyou! I was trying to focus on the visual impact of my product but I realise now that I compromised the structural integrity and usage of it due to the rightly pointed out "a lot of empty space", no "horizontal shelving".

I could change the design so that different components could be bought and placed together - one with a mid shelf and one with a drawer and one with a pull out desk?

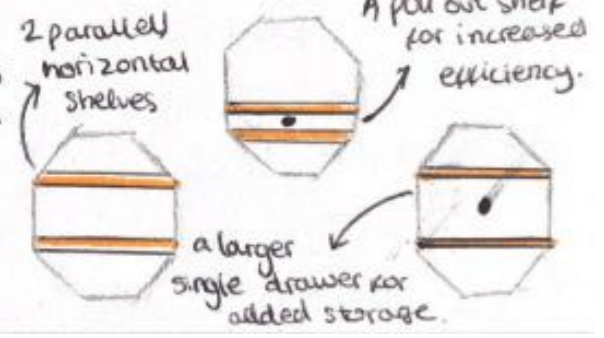

'Backboard' development



dash board effect

adds visual interest without adding a bulky framework.

angles are upright - harder for storage.

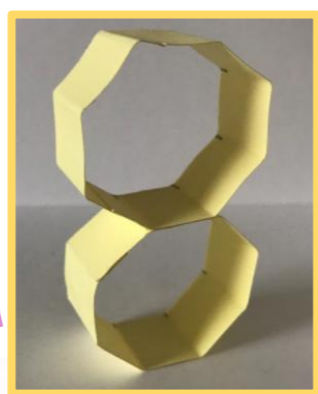

adds on element of user creativity/control.

can be added to and rearranged.

fitting is more difficult for the user as it changes complexity for each added component

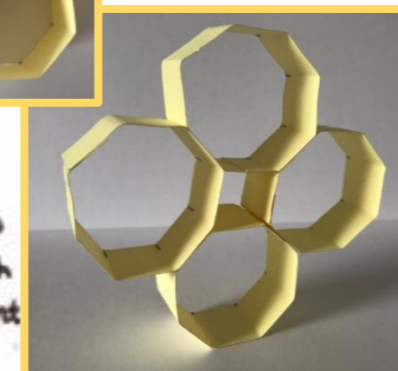
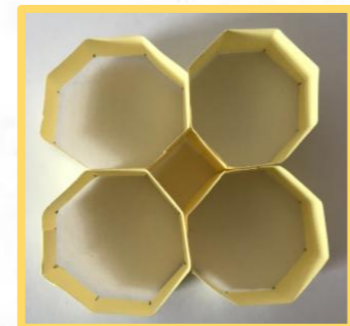

the end user needs to put more effort into construction.

Basis of standard shapes that can then be bought as one or multiple to create a desired product.



60 Films Production 25 Nov  
to me

Hi Emily,

Pros: The look is very original and isn't something commonly seen in most households. They all appear to be wide enough to be not only stable but hold a fair amount of stuff. Some of them (Middle top to bottom) make very good use of space while also keeping the look fancy. The variation in shapes used is pleasing to the eye and could be completed as a set. Some of the designs such as the middle-top one could be used as a bench as it is close to the ground.

Cons: Some of the designs have a lot of empty space either within itself or in space it is taking up. A lot of the designs have do not have horizontal shelving, this would make it hard to place objects on these surfaces. A few of the designs do not look very stable and could easily be tipped over if not enough when was put on the bottom.

Thanks for I agree Thanks for

With these available alongside the original - less efficient design, the user can create a very efficient, unique design of their own using a modular effect.

End user **Callan Wintle** assessing my designs against his view and wants.

Next Step: look into products that can stand up on their own.

Initial Designs

Free standing wall product designs

has less weight pressure on bottom component - better strength.

the 2 sections would be hung separately so could have a gap between.



extra storage space for smaller items.

brackets to make it free standing.

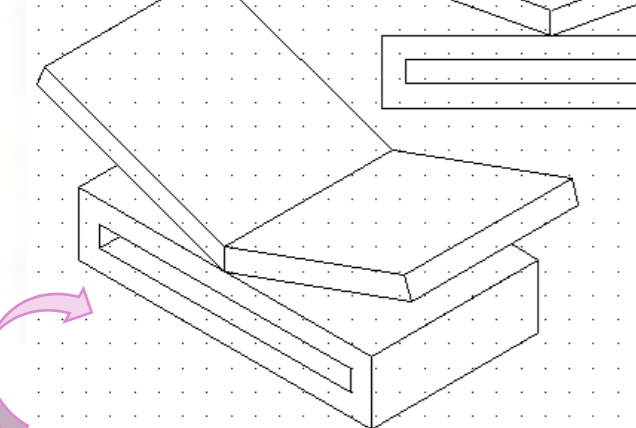

When connecting the two angled top pieces together I could use a biscuit joint at the angle to secure them in place, with many joining points across the seam, especially if the main parts are kept 'floating' separately.

**Next Step:** think about the use of different structures/ parts that could add more interest.

This could work with any of these designs except the hexagon due to its obscure angles.

could easily have a different appearance.

would have to be cleared after each use.

pull out desk

simplicistic extra space for productivity

unvarnished MDF could be used or simple painted MDF for expenses and an easy finish.

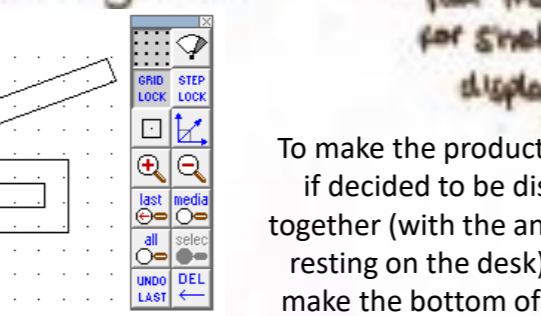

top surfaces are flat making it better for solving and general display/storage.

To make the product stronger if decided to be displayed together (with the angled shelf resting on the desk) I would make the bottom of the joint area flat so it could lay parallel on top of the desk park which means there is more bulk material to secure using screws with high strength.

I like the design of the bottom right because it stands out and is unique. However in the circle design it doesn't look very tall so you ~~more~~ should make the structure.

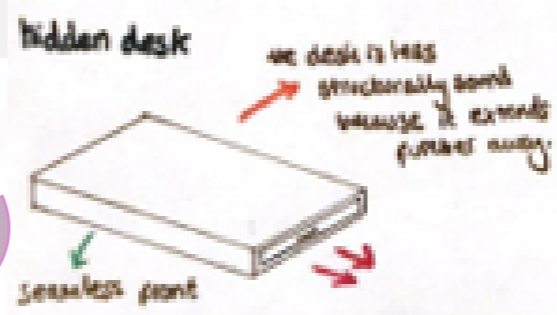

rounded top

aesthetic + simple so would fit in any setting.

lights could be fitted into the edge of the write.

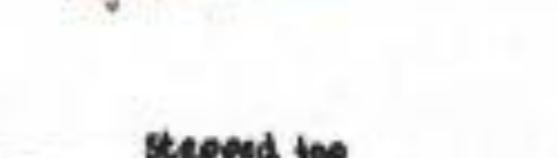

stepped top

small space under top component - reduces visibility

more fixings needed because there is more components.

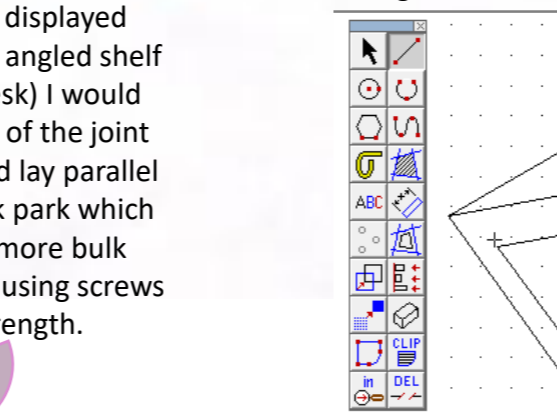

Biscuit joints could be used to join the 6 sides of the frame or bent plywood could be used to give less sharp edges.

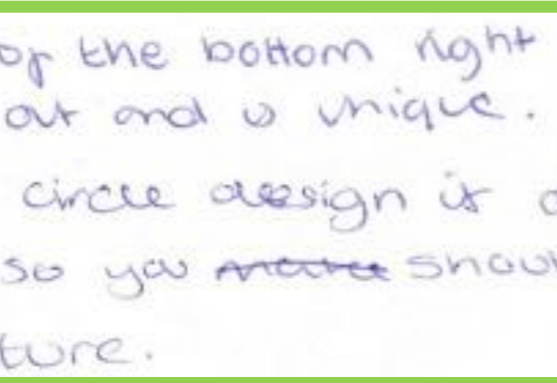

still not that practical as things will topple over.

would be hard to use standard brackets because its rounded.

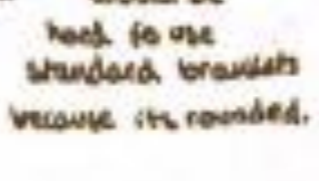

has extra space on the stationary top acting as a shelf.

items left on the desk could fall down the back when it is moved to extend the desk.

wasted space compromised for aesthetics.

roller system only not set in an outer frame

anything displayed on the desk would get in the way when it is extended.

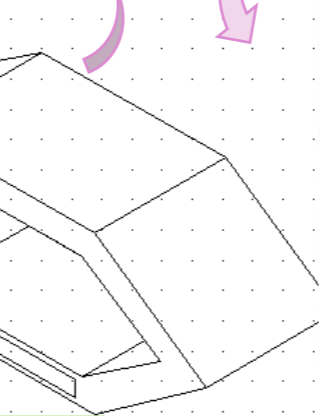

Thankyou! Your opinion is much appreciated. With this circular design I see the issue with the tight space the most tight space, at the moment would only be 1 plank of wood tall - a hand wouldn't be able to grab anything. In order to fix this I could use more, smaller circles, so the height increases quicker or I could add extra components to prop the circles up.

for this design a pole, holding up the tallest circle would have to be used for strength - compromising design.

This design uses prop up poles for each circle so it ties in with the overall design.



Fittings



**Sophie Sutherland**, a primary user commenting on these designs and her opinions of them.

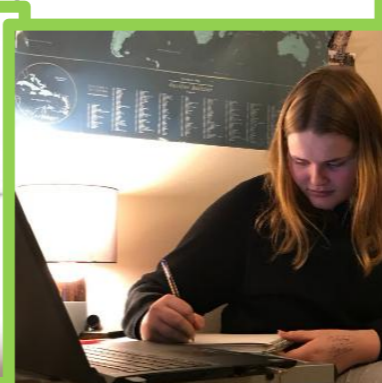

# Initial Designs

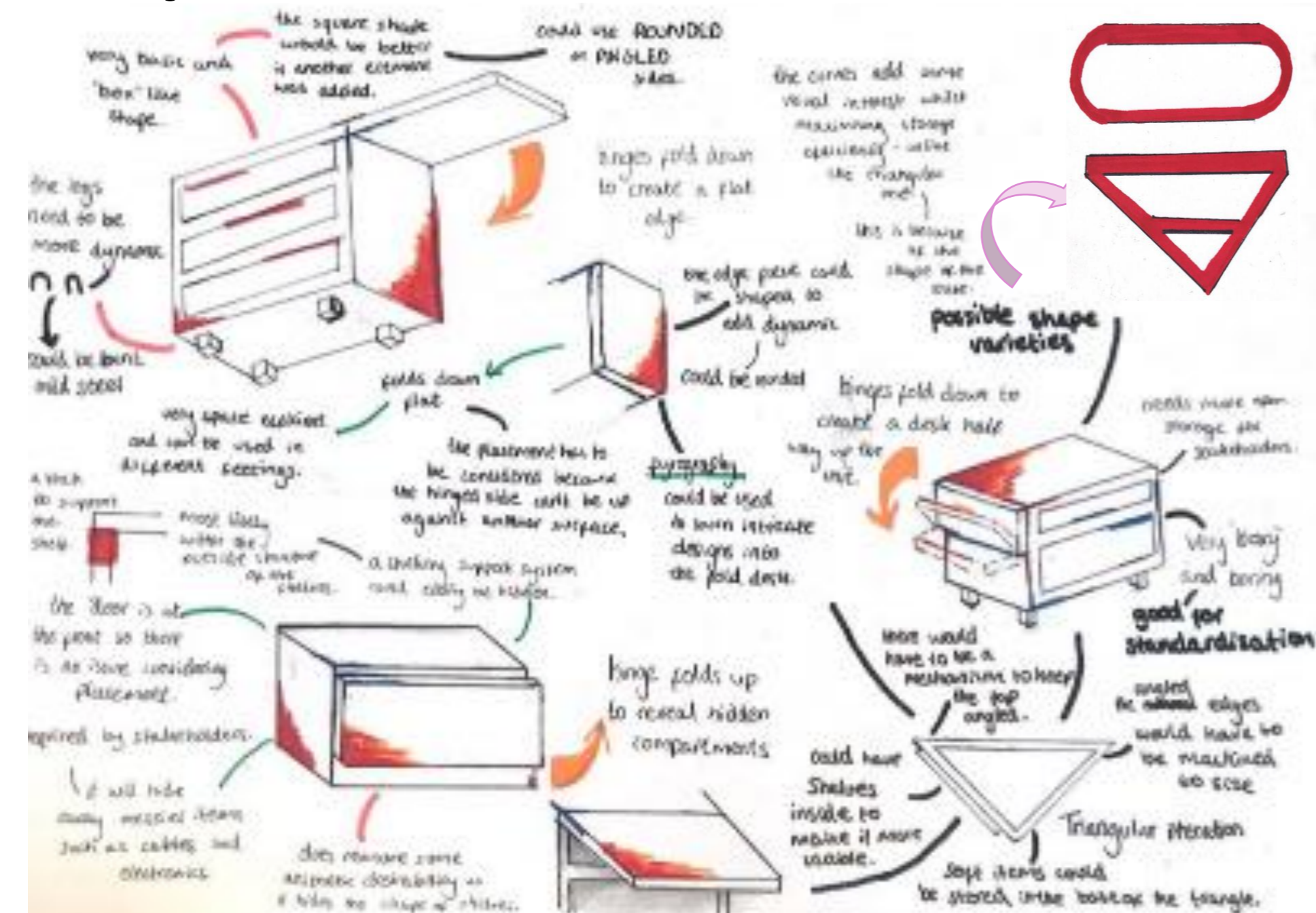

# Hydraulic hinge investigation

I looked up alternative, stronger options to using standard hinges so that I would have less components to consider (there will be no need for a support structure to keep the added surface upright). The two main alternatives I found was an adjustable gas strut and a hydraulic gas metal support.



- ✓ Lightweight
- ✓ Easily adjustable when fixing
- ✓ Uses few fixings
- ❖ Positioning would have to be well thought through to make it parallel when open.
- ❖ Cannot hold much weight when extended- it will simply return to a closed position.



- ✓ More industrialised- more strength
- ✓ Easily set up to the correct angle
- ✓ The gas strut in both allows the part to stay elevated without weakness
- ❖ The bulky design is heavy and restricts space within the compartment it sits in
- ❖ It requires many screws and fixings to hold it in place securely

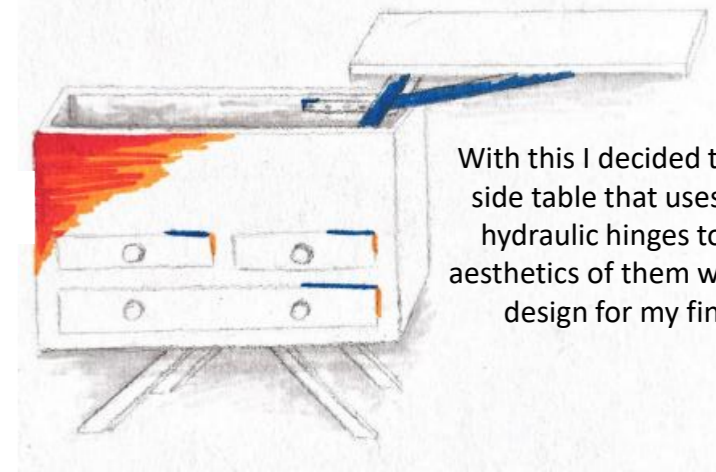

With this I decided to design a bedside table that uses either of the hydraulic hinges to test out the aesthetics of them within a possible design for my final product.

## Order summary



1Pair Gas Hydraulic Folding Lift up Top Table Coffee Table Lifting Frame Desk Mechanism Hardware Fitting Hinge Spring Standing Desk Frame Rack Hinge R Sold by Amoq313

In order to grasp a greater understanding of the hydraulic, I ordered a set of the hinges so I can interact and investigate them further in their movement and dimensions.



**Next Step:** start to develop designs highlighting the feedback I have received and aesthetics.

I like how there is another surface area that is extended out of the piece however I don't like one way the hinge designs are blocky and unattractive. I have never seen a piece of furniture use hydraulic hinges and this concept is much more appealing than the basic fold system.

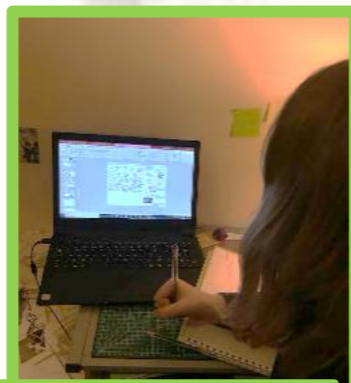

One of my primary users (**Sophie Sutherland**) criticising my designs in order to develop them.

Thankyou once again Sophie. I am striving to include an extended surface area in some way. I agree with the unattractiveness of standard hinges. I have purchased a pair of hydraulic hinges so I will experiment with these to find the correct shape and proportions to use with them. They offer a unique compartment which doesn't need a handle and will give the extra surface a cool 'floating' sense. The only thing is trying to make this less blocky.

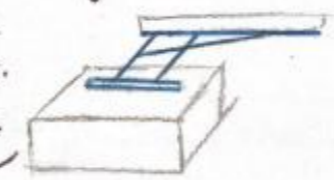

# Design Developments

Before developing my final design, I will collect the main points of feedback from my stakeholders from my initial designs to better design a product for their needs and wants.

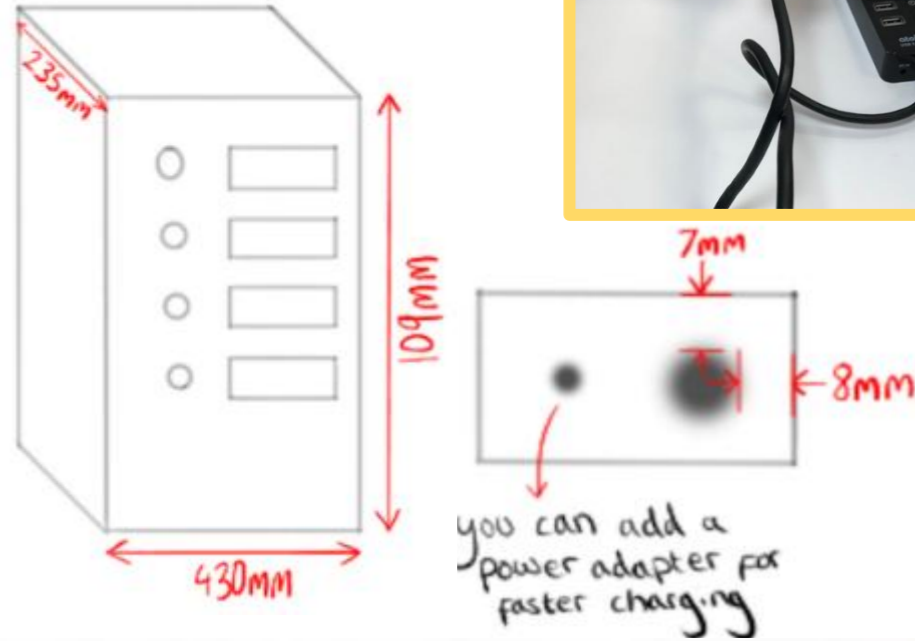
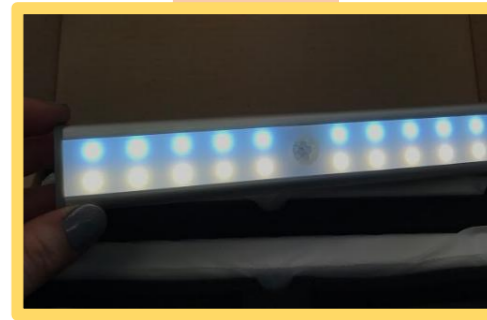

## Common points for improvements:

- attractiveness - some of my designs were **too bulky** and **bulky** or too formal.
  - size of storage compartments - often they were **too open**, leaving lots of empty space.
  - structure - there were a few concerns about the **stability** and **strength** of the overall product and specific joints.
  - shelving - there needs to be some **horizontal shelving** in every design.
  - lighting - stated that deeper compartments could have some form of **lighting**. this is what I wish to focus on and include in my designs for practicality and to make it more innovative.
- ↳ because of this, I want to develop better designs in mind of my feedback. My first steps will be looking into technology accessories to improve my designs.

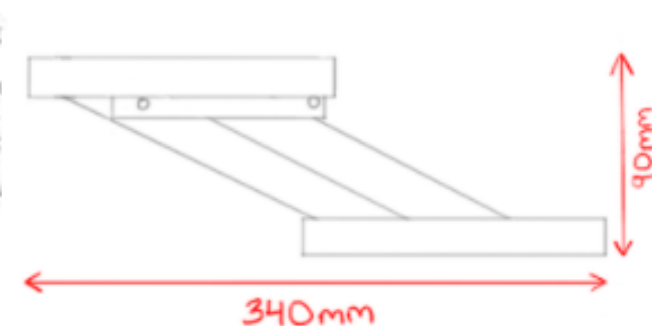
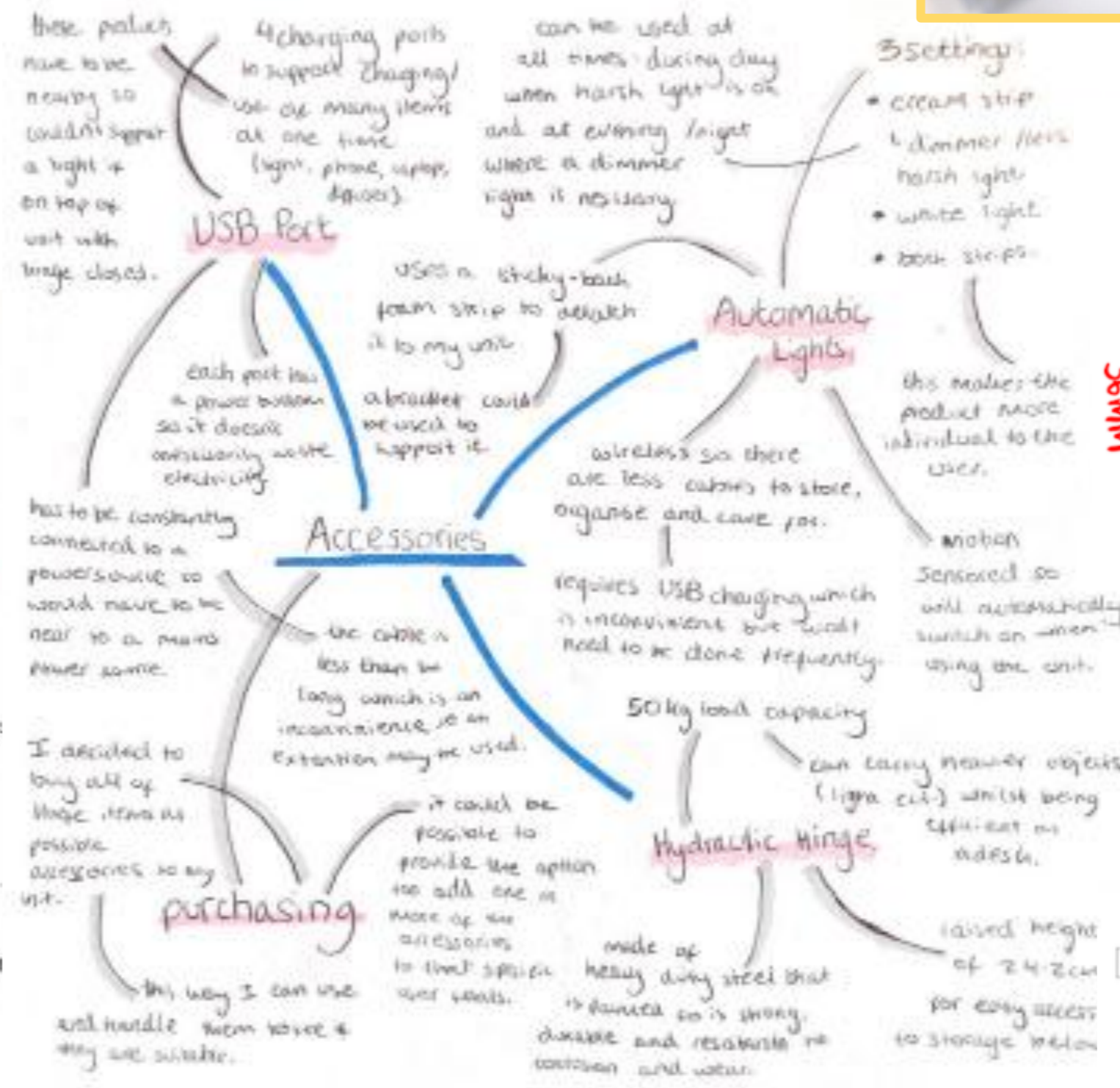

**Next Step:** look into working with the hydraulic hinge to get an idea of the size and look of the piece.

# Design Developments

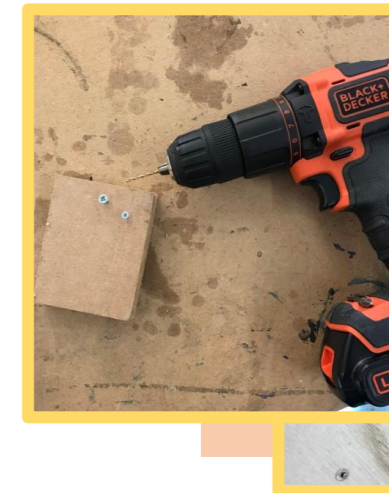
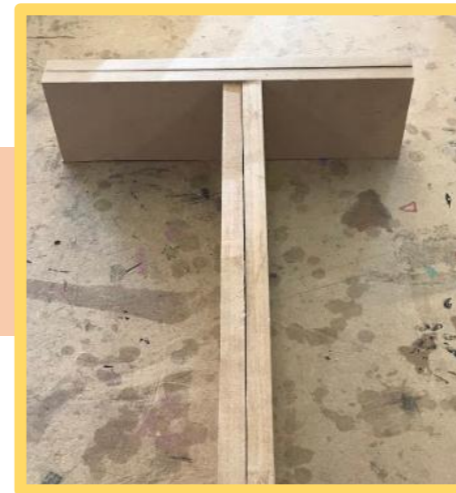

Once I had bought the hydraulic hinges I wanted to test them to visualise and develop the size and aesthetics of the top component they are used in. In order to do this I built a basic but accurately sized model that I can physically use.

To begin my mock up I measured out 4 lengths of wood scraps that were all 10cm deep. For the longer sections I measured and marked out 60cm strips and for the shorter I used 39cm lengths. I used a hand mitre saw at 90 degrees to get the best accuracy I could.

I used an electric drill and a small piece of scrap wood to practice drilling and screwing using appropriately sized screws for my hydraulic hinge and for a simple butt joint for the framework. This allowed me to gain confidence and better myself at using it properly and effectively.

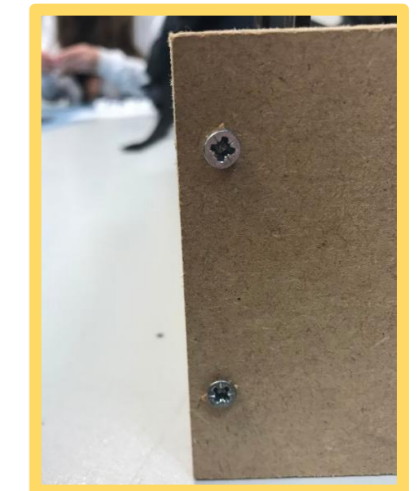
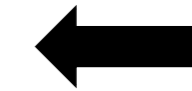

I found a piece of wood from a collection of used pieces that is 61cm by 45 cm big to use as the top of my mock up (giving a 1cm and 3cm overhang). I flipped my rectangle frame upside down onto the top piece in order to mark out the places for drilling screw holes in order to screw the hinges onto the top component, completing the model.

With my frame work complete, I marked out the positioning of the hydraulic hinges within my frame so that they manoeuvre without hesitation when the movement is triggered and sit flat against the tops of the sides. Using these markings I attached the hinges to the inside using a small set of screws.

With this skill, I drilled 8 holes (2 at each joint) and screwed my 4 framework edges together with simple butt joints to achieve an easy, squared off, rectangle frame.

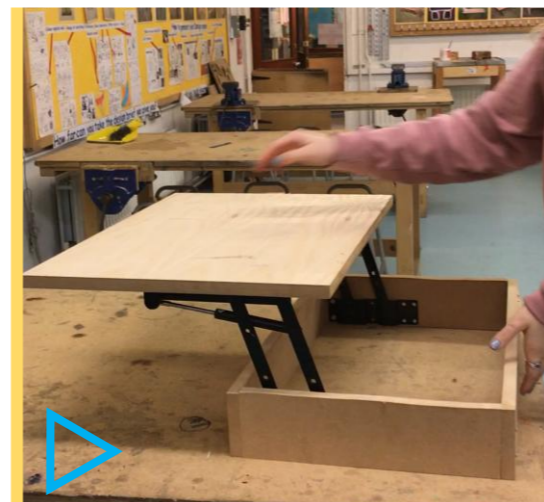

Video of me using the hinge, opening and closing the top compartment to show the ease of use.

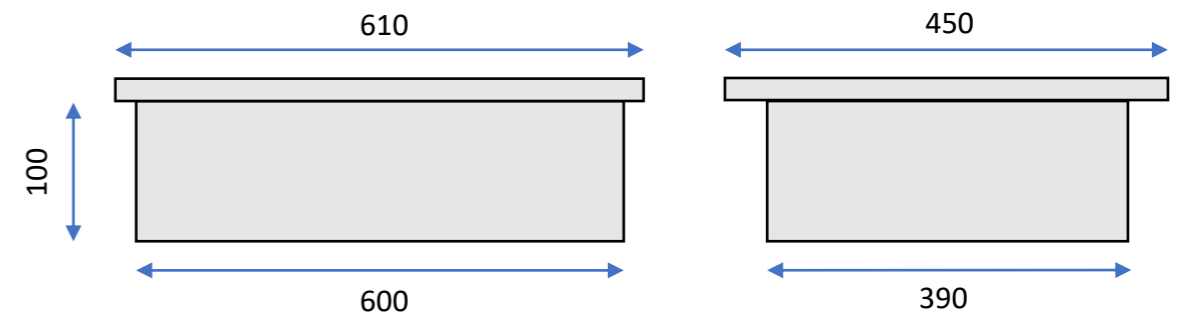

All dimensions shown above are in mm



Different angles of the model in its closed position.

**Next Step:** assess the model in terms of use and limitations and develop it further to improve the design and prototype. Get external influencers to comment on the model to gain broader opinions to get the best product possible.

# Design Developments



The light attached to the model in the position it is likely to be in for the final piece



The charging port could be attached to the side of the wall, similar to the light however this wastes space so it could be set into the base of the compartment.

**Next Step:** look into different possible shapes of the final product that are able to include this rectangular hinge top compartment.

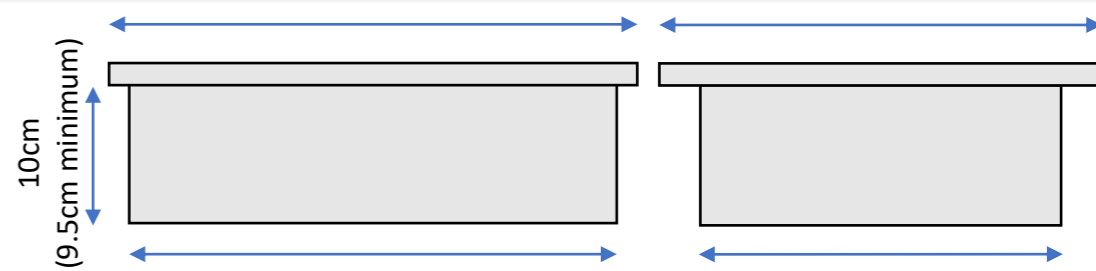

Because of this, I decided to tweak the dimensions and the placements of the brackets on the model to see how it would function in a more realistic version.

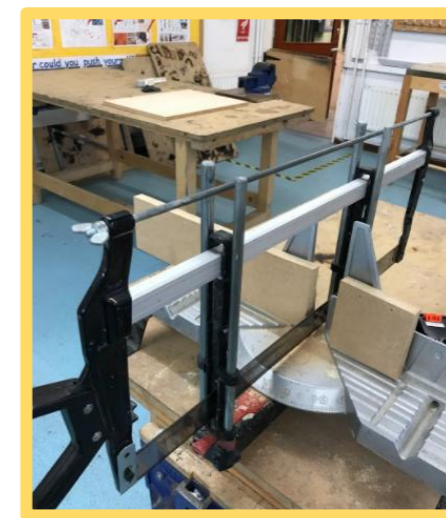

I used the same process as the previous model.

I used the same wooden planks for the sides as last time. This saved materials and made less waste.



I placed the brackets along the front and back so it opens sideways.



I used a scrap piece of thin MDF. This wasn't good because it was too light to hold the bracket in a closed position. In my final piece I will need to use a solid plank or heavier piece of wood for the top.



# Design Developments

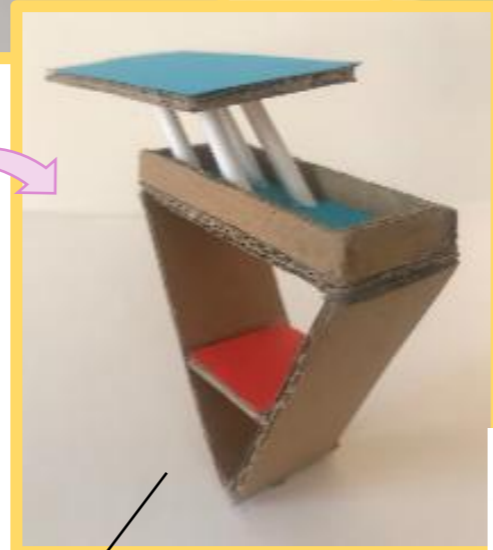
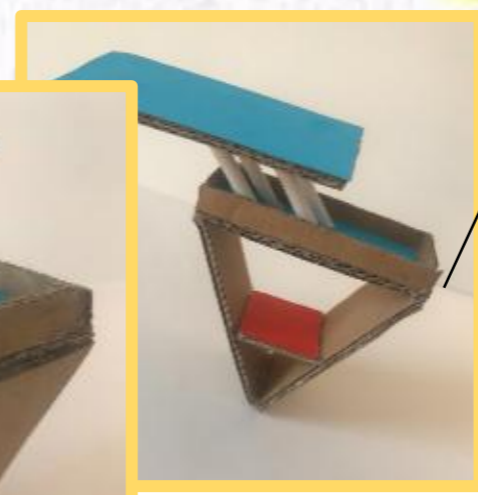
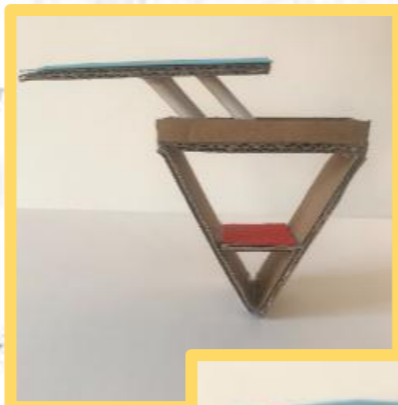
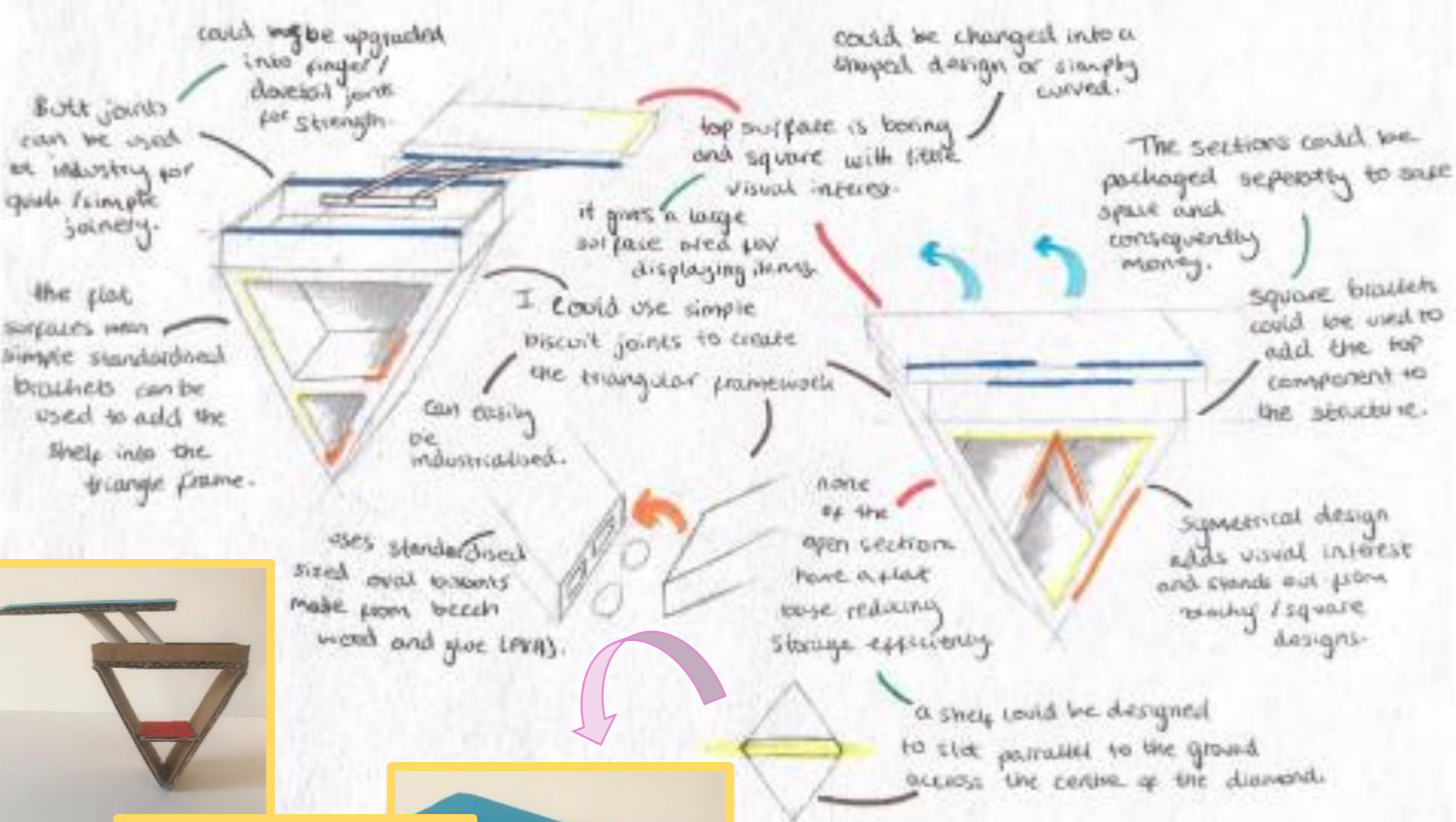
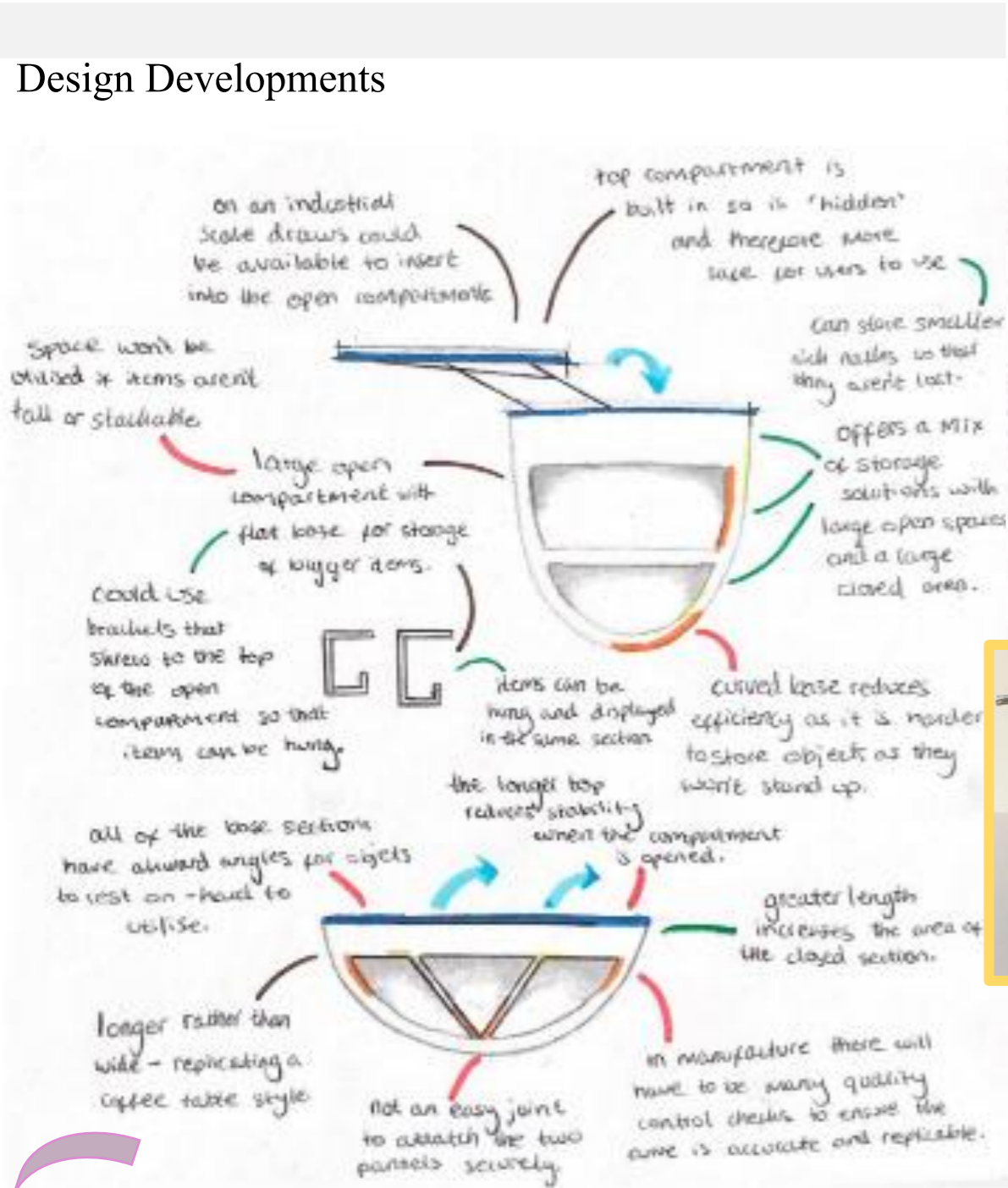

The card made it hard to bend making the edges not smooth as it would be if made from plywood.



I made some quick models to represent a few of my designs in real life to visualise the viability of the design for manufacture.

The angles would have to be well thought out and marked and cut in order for the piece to slot together accurately.

Fitting the shelf into the bent frame proves difficult and hard to get completely level - before I would produce this design I would put all of the measurements into a CAD software in order to have a scaled drawing that I can use to base all of my processing steps off of.

The flat planks that would be used to make this product are easier to work with than bent wood.

Both look very modern. I like the way the top compartment fits into the rounded frame. Out of the designs I prefer the two triangle ones and out of these I prefer the one with flat shelf. This is because there is adequate space for open and closed storage whilst the asymmetric design isn't practical. I would like it more if the top compartment was built into the triangle or frame as it is in the rounded ones.

End user Sophie Sutherland commenting on my designs



My Response:

Brilliant, thank you for your opinions, I will continue to persevere the triangular designs. I have added the top component as discussed.

Next Step: follow up on the triangular design to develop it into a feasible design for making.

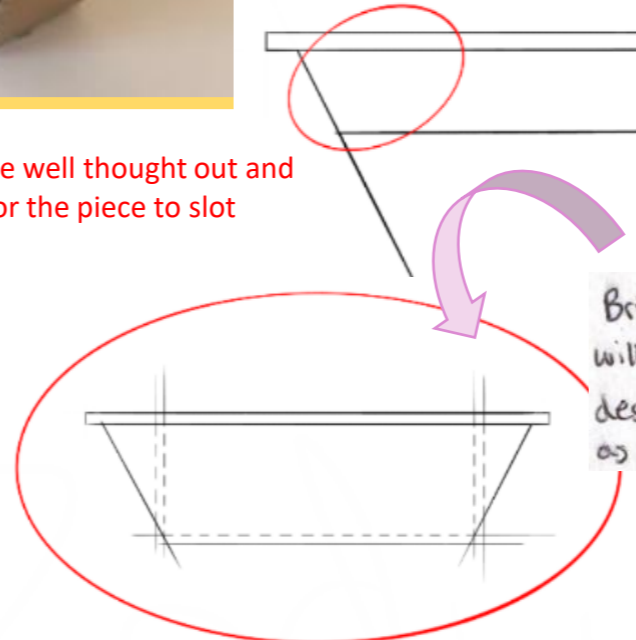

# Design Developments

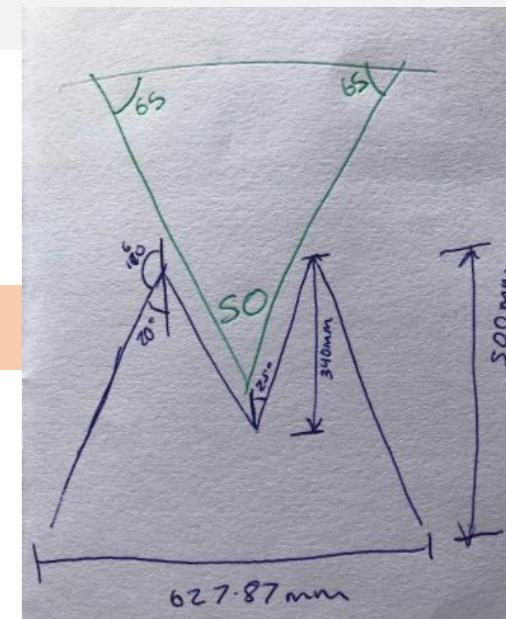
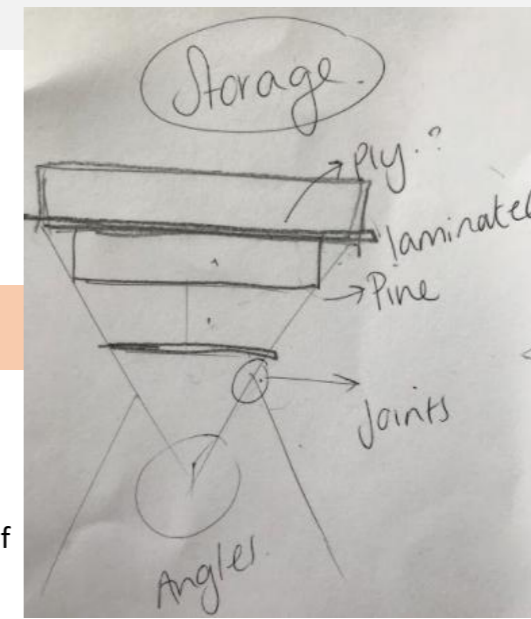
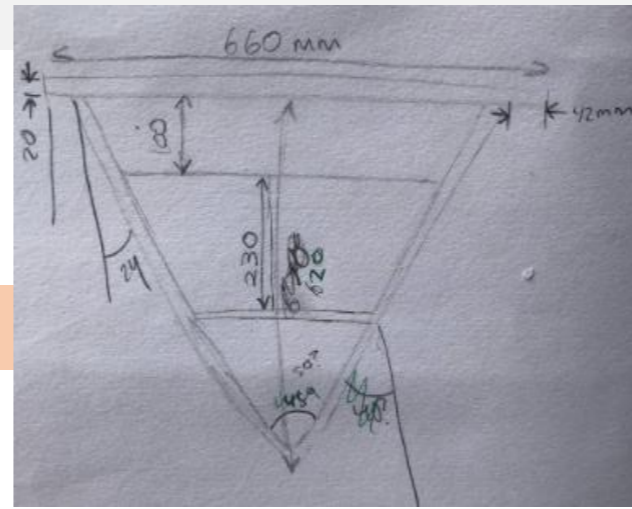
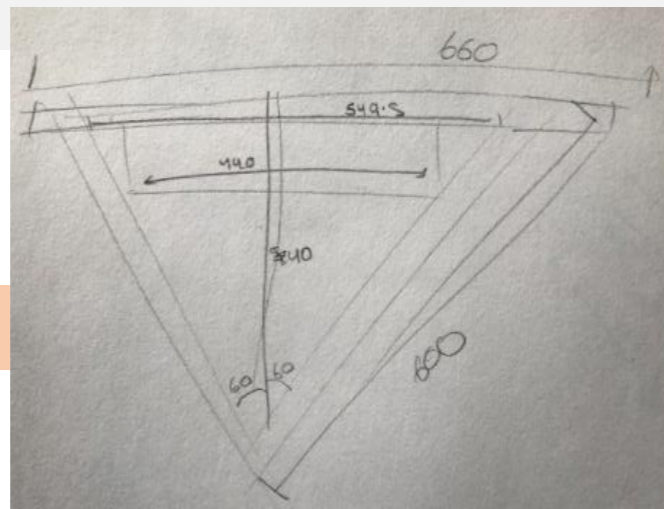
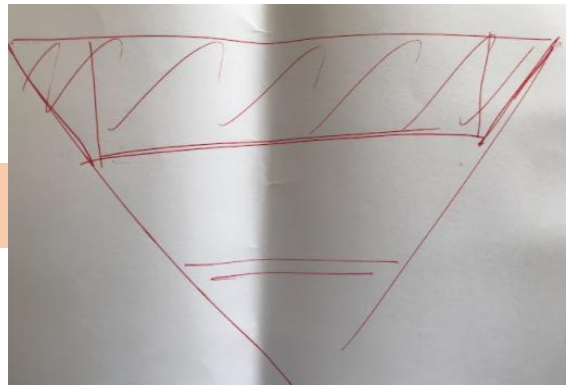

Using the triangle idea I did a series of basic sketches in order to decide on **measurements and angles** of my final piece. These are quick, simple visuals of my design that I translated onto **2D Design V2** CAD software in order to further develop and finalise the angles and sizes of components I would need to prototype.

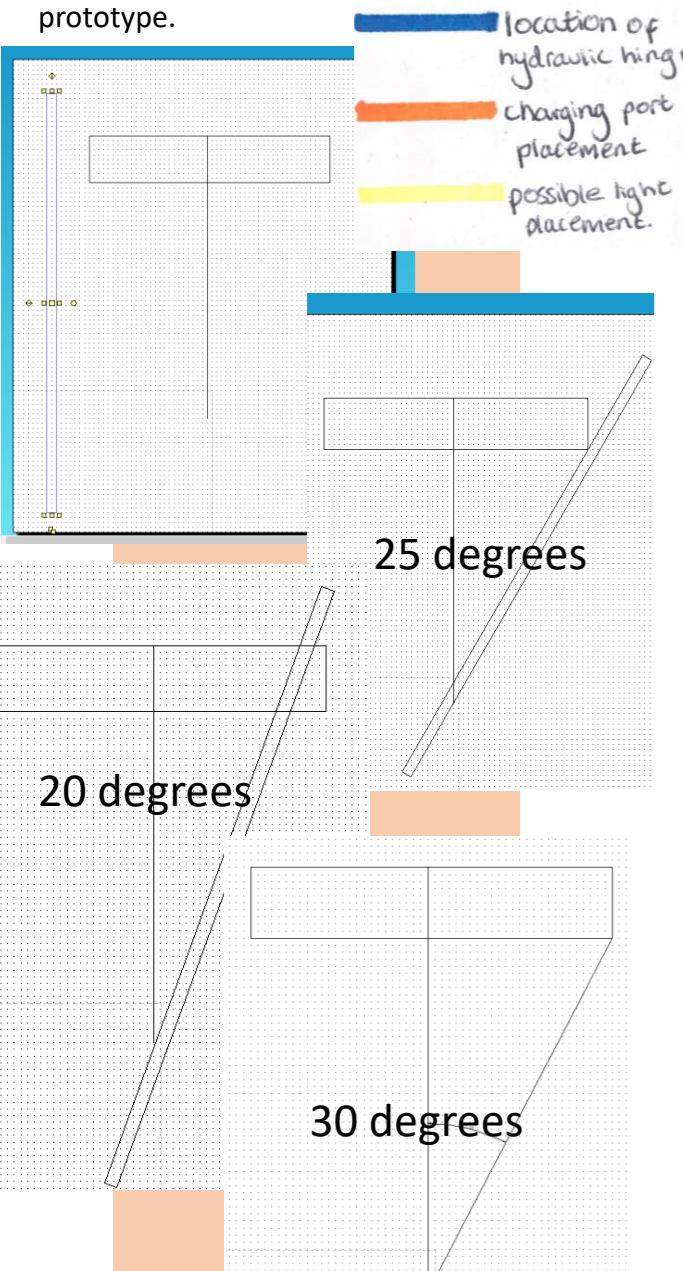

25 degrees

20 degrees

30 degrees

I decided on 25 degrees for the angles of the two sides as I believe it best suits the piece

the slanted shelf restricts the storage/display of taller objects

limiting efficiency

there's a balance between flat shelves and angled - aesthetic and proportionate.

flat shelves are more efficient.

slanted shelf reduces efficiency as less items could be stored on it, especially with the V base.

the width of the flat shelves are thin - wasting space as it widens with height

the charging port will be bolt into the base of the top compartment so it is out of the way

it may have to be supported by a metal bracket or equivalent.

lots of small spaces for storage makes it less versatile as a much smaller range of products can be stored.

geometric design has a similar concept throughout (no random curves or diagonals).

gives it a less chaotic look and simple construction as there's less angles.

the joint at the base of the structure will have to be strong enough to hold all the weight and components.

all of the vertice pieces can be joined using the same router technique.

a depth stop curve used to make them identical and accurate.

there is a lot of shelving components which will compromise strength as weight is dramatically increased.

there are many possibilities for the light placement meaning users could decide themselves. - more personal.

having the extra angled shelf will make construction difficult as a clean joint would be hard to achieve.

could use brackets to strengthen it but it will look untidy.

limited shelves reduce production costs and maximises storage variety.

the flat shelf could be made more efficient by having the vertice 'shelf' be half the width of the outer framework - giving a larger surface area.

careful consideration will have to go into the construction of the triangle framework.

wood/metal joints??

basic shape with perpendicular shelves - easier construction than adding more angles.

I would route indents in a straight line into the flat shelf and the underside of the hidden compartment for the vertice 'shelf', to slide into

but still easily accessible

aesthetically eye catching whilst still being a basic design.

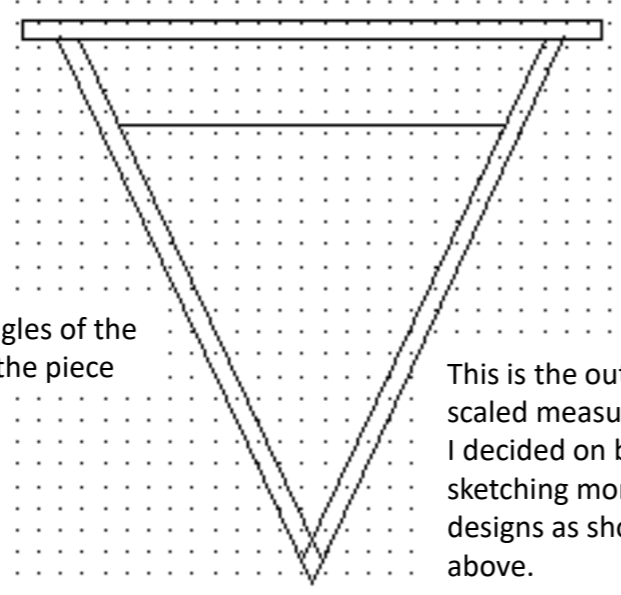

This is the outline with scaled measurements I decided on before sketching more initial designs as shown above.

**Next Step:** continue to develop the triangle top component design by making laser models and considering manufacture.

**CALLAN**  
I like the second design the most as it looks to be the most practical and sturdy. It is also quite unique in style the upside-down triangle shape is a nice change to look at. The only downside is the bottom of the triangle doesn't lend itself to having any placed on if as it is not a flat surface. When it comes to the compartments I prefer the middle one, it allows access from both sides as isn't so confined that only small objects could fit into it.

Stakeholder Callan Wintle commenting on these deigns

**My Response:**  
Thankyou, my thoughts were this base compartment could be used to store soft things such as blankets but as you say, this isn't very versatile and some people will not want that. I could take this off so the base is flat but from other responses, stakeholders on the whole have tended to like the triangle aesthetic.

# Design Developments

## Construction out of wood:

- I would use 18mm thick laminated plywood or oak veneered MDF.
  - ↳ these would have a natural finish - varnish/stain.
- I would use a mitre saw, set to 25° to create accurate, identical angles for my prototype. For industry, a powered mitre saw could be used or a large table top saw that could process multiple at the same time.
- + It will give a good contrast to the fully metal leg framework and can be in contrast with the overhanging top if that gets painted.
- The base angle where both sides at 25° meet to form an inner angle of 50° is going to be hard to make with similar strength to other joints. As it is the base it needs to be incredibly strong to support all the weight on top of it.



To overcome this I could cut the wood so that one edge would essentially sit onto the other so I have an easier area to work with to put a joint - biscuit joint / mortice and tenon.

## Construction out of metal:

- I would use 20mm square mild steel tubing (thinner than the leg framework), brazed together in a jig, similarly to the process of the legs.
  - ↳ I would use a heat torch and use brass/copper to melt and seal the joins in the mild steel.
- For the shelves I will use 18mm laminated pine to sit into the metal frame. This would make all edges flat whilst still practical.
  - ↳ I could also cover the exterior of the metal in wood veneer to give it the same contrast as discussed with making it out of wood. However, this would be more expensive.
- + Strength wise, using metal is the safest option to achieve a guaranteed strength, whilst being more simple to make, so perhaps better for production on an industrial scale.

- It doesn't give the same contrast and visual appeal as the wooden one. This is something highlighted by stakeholders as a want as nowadays fashion and trends are upmost important.

I put my design into a scaled CAD drawing, using a set up page size of 1000 by 1300mm. From this I am able to finalise my angles and measurement for this top shelving section.

I then set up the drawing to be cut out of 3mm plywood from the laser cutter. This is a scaled model, giving me a true representation of what it will look like in a natural setting.

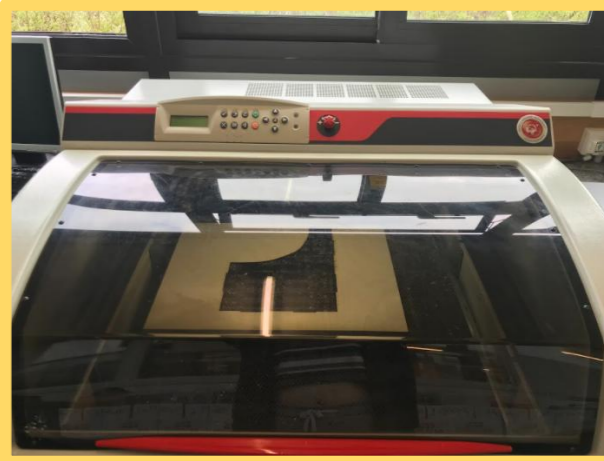
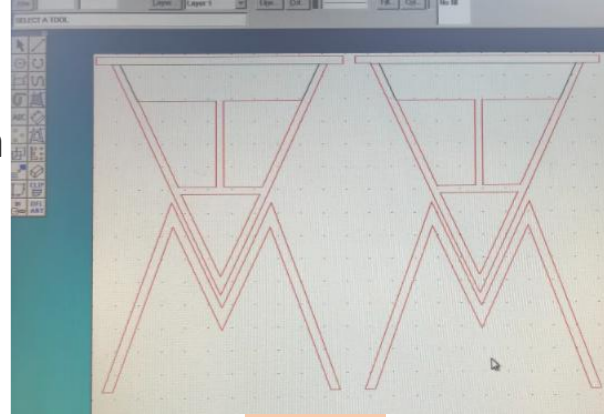
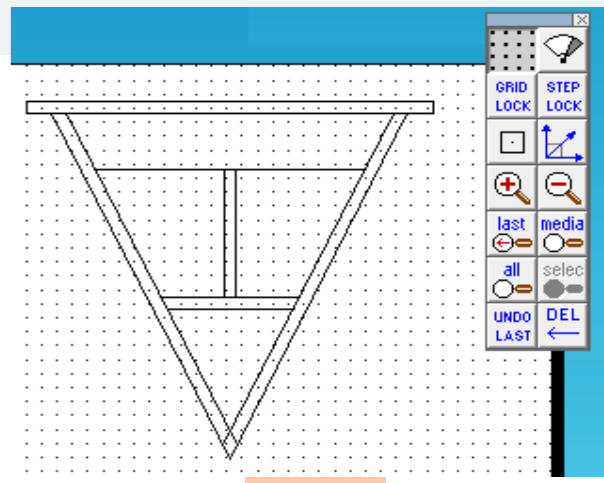

The importance of not sitting still for too long has been shown by all the home working during the last year. Therefore, having a design that can be used sitting or standing is a very good idea. The geometric design has nice, clear lines, while the top unit provides the USB charging facilities that we all need these days. The design matches practicality with style.

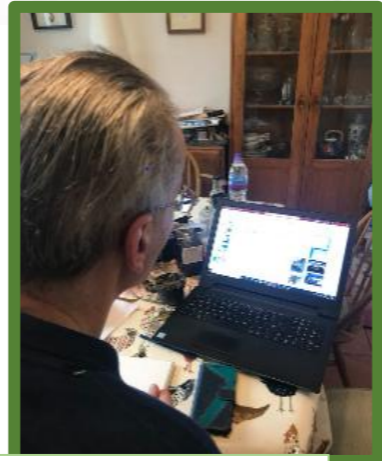

Stakeholder James Sutherland commenting on my CAD model and plans for making.

**My Response:** Thankyou for your agreement and understanding of the designs I am developing. It is clear that I am on the right track by using the hydraulic hinge and USB charging port as this is making it more appealing to my stakeholders. I remain undecided about my plan of making for the wooden section but this support from stakeholders means I will have a concrete plan soon.

**Next Step:** look into different options for the legs of the design that are suitable for the current design developments.

# Design Developments

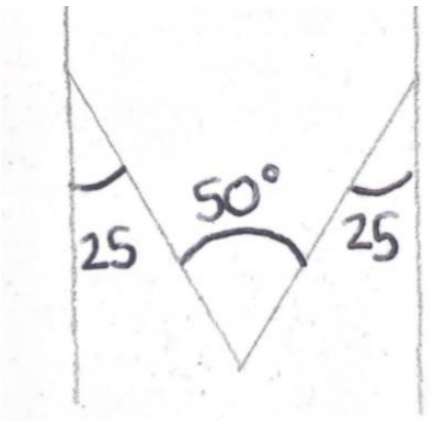

It is an eye catching design but the integrity is compromised due to the lessened strength

The later issues with the design came when considering how the bottom point of the triangle would sit inside of it without fear of movement or collapse. Because of this I decided that copying this shape wouldn't be feasible as the would wouldn't sit into the design so I cut off the bottom of the triangle point so it neatly sits inside.

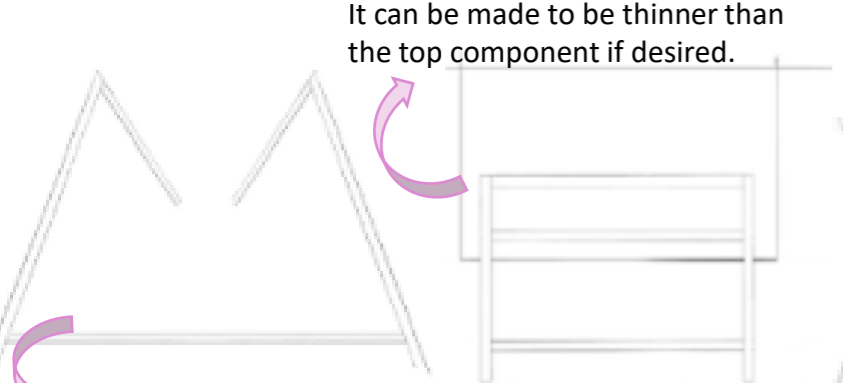

The gap in the centre of the design allows the triangle base of the top component to rest inside

**Next Step:** put my design onto CAD and finalise the sizes of component in order to assess how I will go about building such a product.



Bending the metal to such a gentle curb will be difficult



The angled legs look aesthetic whilst being easier to obtain to a high quality

I started with two basic designs and chose which would be more feasible. From that I developed the chosen angles framework design. I then used the same tactic in the second round of designs, choosing which I believe to be the most feasible and best for the end product. Structural integrity was my main focus for determining which would be a better design.



This design works with the triangle shape of the top but strength is still an issue here

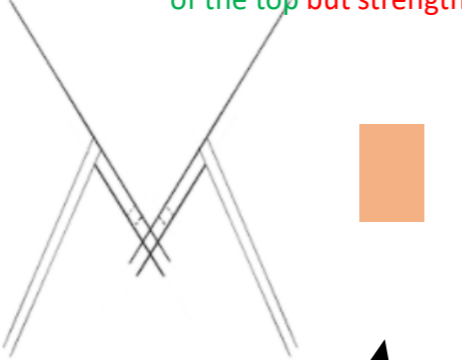

High strength and good aesthetics, the only issue is that the wooden top wouldn't be able to sit inside of the framework as it would sit on the centre of the M- balance issues.

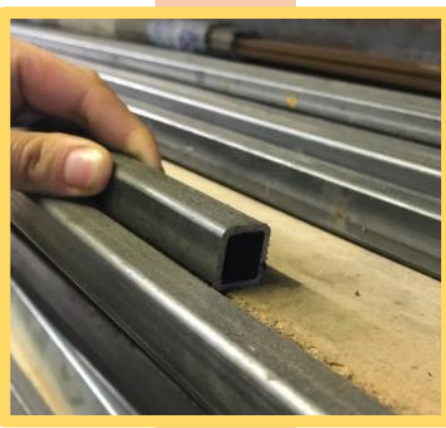
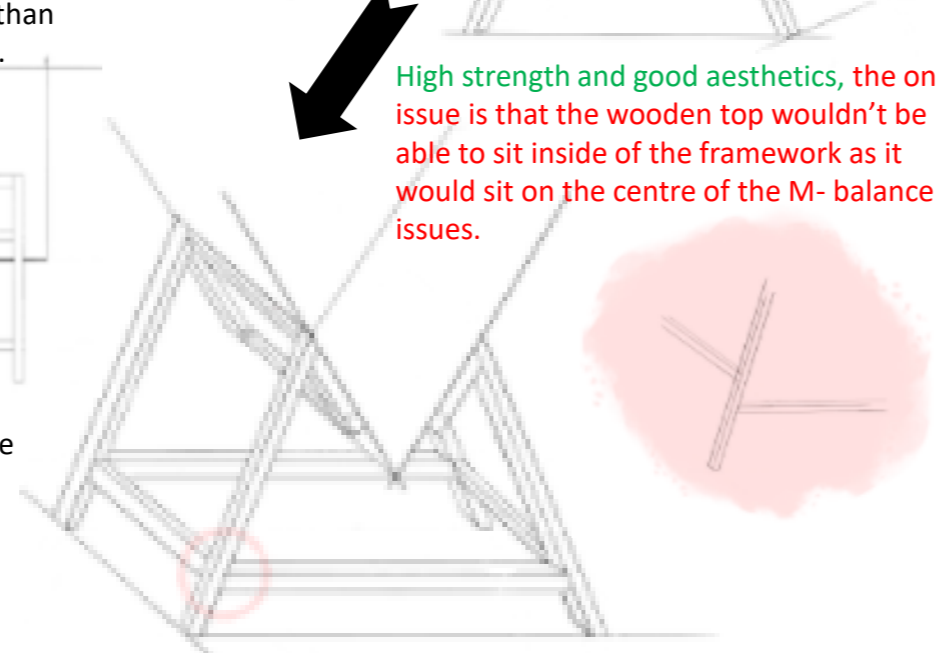

## Brazing mild steel:

- there are many standardized sizes of mild steel tubing available to me including: 20/25/30 mm square, 15/20 mm round and larger rectangular tubing.
  - my designs revolve around 25mm square tubing with thinner round pieces for support.
  - I will use brazing using brass or copper rods to join my metal pieces together in a simple process:
- 1) quality checking the metal and measurements I am using. With this I will create an accurate jig of the flat sections so that they are identical and ensure highly accurate dimensions.
  - 2) cleaning up the area of the joints using sand papers and clothes. this will then be coated in flux, a chemical compound that prevents the metal from being affected and damaged by the heat used.
  - 3) brazing - with the metal in the jigsaw jig to keep it all in position as the steel is heated using a blow torch (with multiple fuel gases). the brass will melt and cover/fill in the gaps between the metal.
  - 4) once cooled, the flux residue will be cleaned and an angle grinder will be used to clean up joints.

**CALLAN**  
The progression of the designs shows real thought and consideration into the logistics of balance and security of the shelving unit sitting above. The issue I have with the last design is that by removing the central connection the weight of anything placed on top would surely push the metal framework apart, compromising any strength in the framework.

Stakeholder Callan Wintle commenting on these designs

**My Response:**  
Yes, I have realised that the openness of the last design will mean that over time the edges will be pushed outward due to weight and gravity, breaking the framework. I will work on adding in more supports where needed.

# Design Developments

I put my proposed design onto 2D design software where I could visualise it to a rough scale. It was then easy to quickly add components, change parts and tweak around with the idea (adding support beams and playing around with their position, etc.) At different progressions I used the laser cutter to cut the framework out of 3mm plywood, attached by pieces of wooden dowel cut using the band saw.

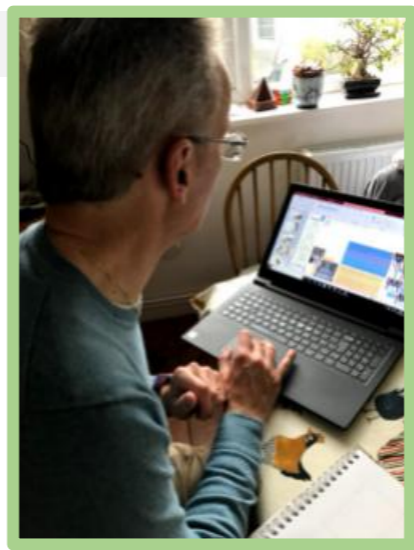

The evolution of the design takes a reasonable balance between the competing demands of stability & weight, while maintaining an elegant form.

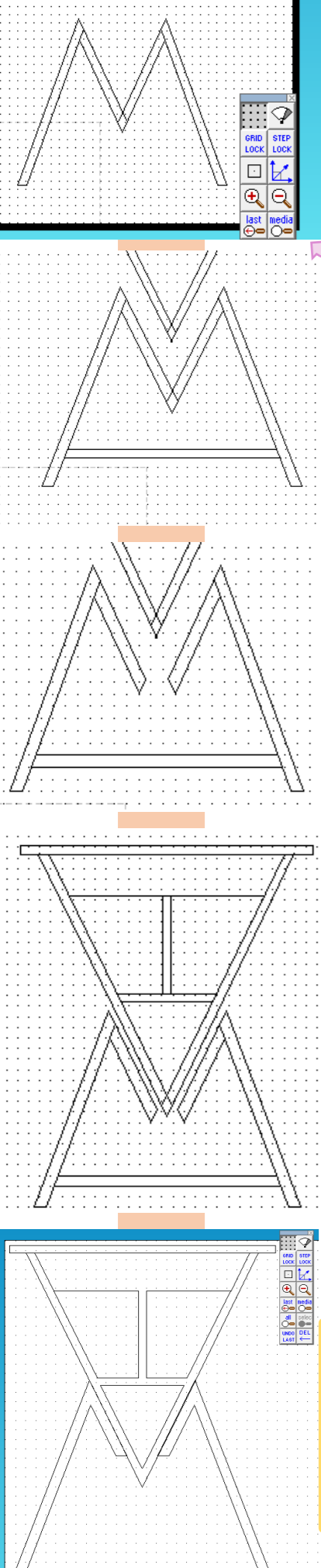

My main points of focus:

- strength - any design I make will need to be strong enough to support itself and additional weight from items being placed on shelves.
- aesthetics - I need to continue to steer away from basic or boxy shapes to add visual impact and interest for the user.
- stability - I would like to model multiple of my designs to test and see whether they stood upright without any wobbling as this is a big concern because the frames will be attached together.
- durability - I will consider different finishes that I can use on the metal frame that would suit aesthetics whilst enhancing durability such as powder coating.

Stakeholder James Sutherland commenting on the progression of my designs displayed on this page to give me critical feedback for further progression.

My Response: Thank you. That is exactly what I was hoping to achieve with multiple iterations to slowly progress my design to get better and better. I am glad to see it paying off with the support of stakeholders as I continue to involve them in finalising my design.

The first one I laser cut was the simple M shape one that I previously proposed on the last page. I did this to visualise the extent of the issue with the top piece not being able to fully sit into the frame rather, it simply sits on top. I realised that this didn't make this small model too unstable as the top frame and bottom frame were made to the same proportions exactly. **This would become a larger issue when the product is made life size as the length of the central V of the metal framework would not be long enough to support the height of the wooden frame so it would be unbalanced and unstable. This will then be exacerbated by the fact that it will be near impossible to make a final prototype where all the angles and measurements align perfectly due to human error.** The good thing was that I could easily play around with the placement of the dowels to see where I could place 2 within the central V for the triangle base to sit into if the downward facing triangle tip of the frame be removed. Quickly I realised the need for more iterations whereby the overall shape of the frame is moved on from the simple M for functional purposes.



This is the second design I laser cut. This again is a not to scale as I simply took the CAD drawing from the last model and changed aspects by initially removing the base of the triangle tip of the frame and **slowly building up the strength of the frame by adding support pieces across the front of the piece to hold it all in place.** Once I had a rough idea I printed it to see how well it worked with the wooden frame and it was considerably better than the last model in terms of balance and stability. With this one, the dowels could be made to be shorter than the width of the shelves so that it fully sits within the bounds of the metal framework, should that be desired. I was once again able to play around with the positioning of the dowel whereby I changed the amounts of support pieces could be used. **The more I used, the greater the strength however, in a real life product, there will have to be a balance as the weight would increase significantly with every added piece fixed on.** Therefore, I will continue to fiddle with the amounts and position of the support pieces in order to obtain the best balance of strength and manageable weight.

**Next Step:** laser cut a scaled model of the legs that I can attach to the model of the shelving component to see and interact with an accurate model of my final design.

# Design Developments

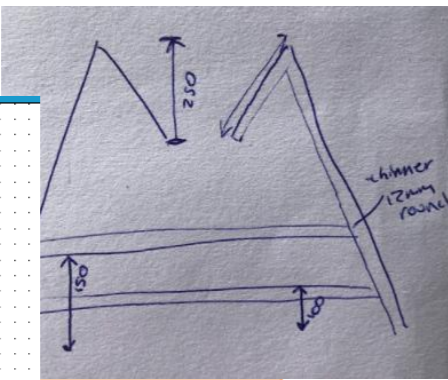
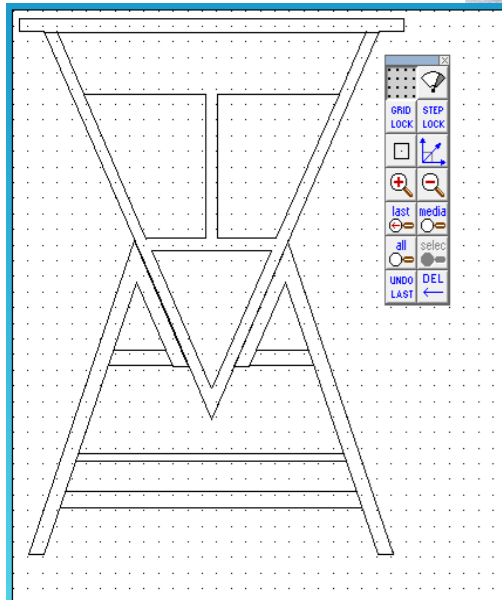

I used my CAD drawing (2D design software) to template/draw out my leg frame to a scaled estimate of sizes that looked appropriate. I used quick, basic sketches on rough paper to plan out possible sizes which I scaled down onto CAD to develop my fully scaled drawing which I used to laser cut my plywood model. With this I played around with different possibilities of the model, as shown and evaluated in the pictures.

Because the top component is not attached to the base, it is a possibility that it could be flipped upside down to add versatility. It adds another aspect of user individuality as they can decide how they would like to keep it. The downfall is that the closed off 'top' component (now at the bottom) would not be accessible as the weight would not allow the hydraulic hinges to open.

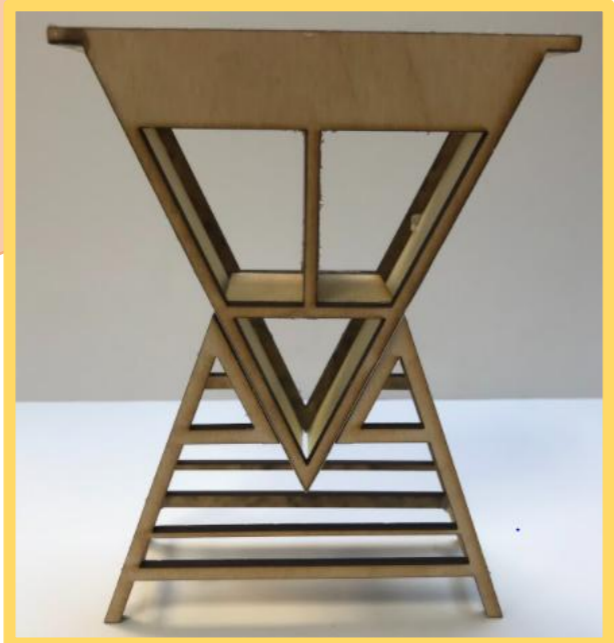

## Product Description + meeting stakeholder needs:

- Roughly 800mm tall, 300mm wide, 600mm long storage unit with 3 open compartments (2 of which are flat based) and a 'hidden' storage facility located at the top, accessible by a self-supporting hinge.
- It is compact with a range of compartments making it an ideal small unit for any person with a small space.
- The mild steel base with laminated pine top work well together to complement each others finishing (powder coating / paint to stain / varnish). This allows users to obtain a stylish, sleek finish whilst having practicality in the form of abrasion / wear resistance.
- Lighting and charging components can be added into the hidden compartment and on top of shelves to allow light-up and charging services - making it multi-functional and better suited to a wider range of users.
- Multiple support beams on the mild steel framework resist pressures from weight and strain from the moving hinge to make it durable and long lasting.

The triangular storage unit could be retained as a modular piece whereby it could be split into 3 units: the smallest base triangle, the split shelf and the hidden compartment at the top. This way the end user could decide how much storage they would benefit from which would vary the height and shape of it. It would make manufacturing much more complicated as there will be more components and some sort of fixing would have to be arranged to align the components if stacked on top of each other.

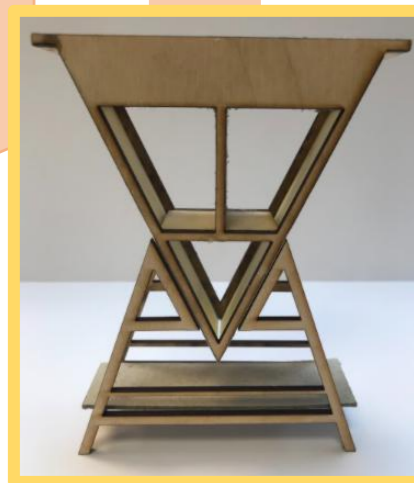

A shelf could be added across the bottom of the metal framework. This would add more storage and therefore better the efficiency however, it would add more weight and there is not much height between that and the other shelving so perhaps not worth the extra cost.

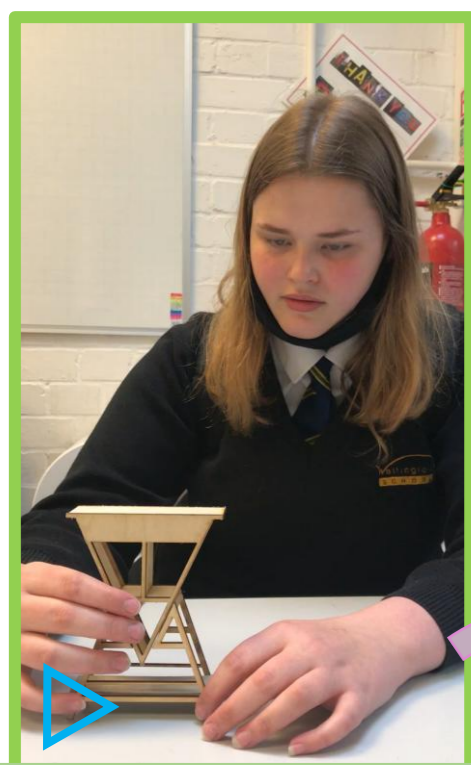

my response: thank you, I aimed to make something that was versatile for many settings including an office as it a good, well rounded storage facility. The multitude of compartment helps to achieve this, however I do understand your concern about the weight. When manufacturing / planning to manufacture I will consider if some material could be removed / made shorter to reduce overall weight.

Stakeholder Sophie Sutherland interacting and commenting on my model of my final design. Her main points are "it is versatile so would work in different locations" but "there is a lot going on so it would be rather heavy" She liked how it isn't attached to the metal legs so it has the potential for being a wall mounted design but once again, the weight of the wooden frame may hinder this possibility.

**Next Step:** create a display page showcasing my final design.

# Final Design

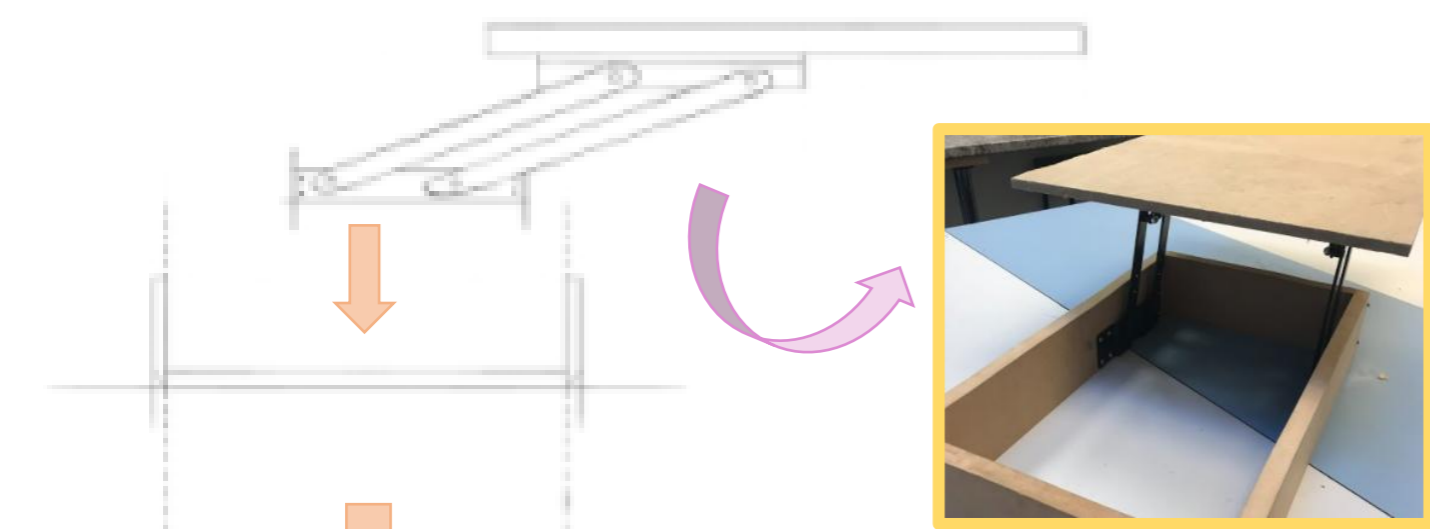

Hydraulic hinge to open the closed storage space and extend the desk upwards.

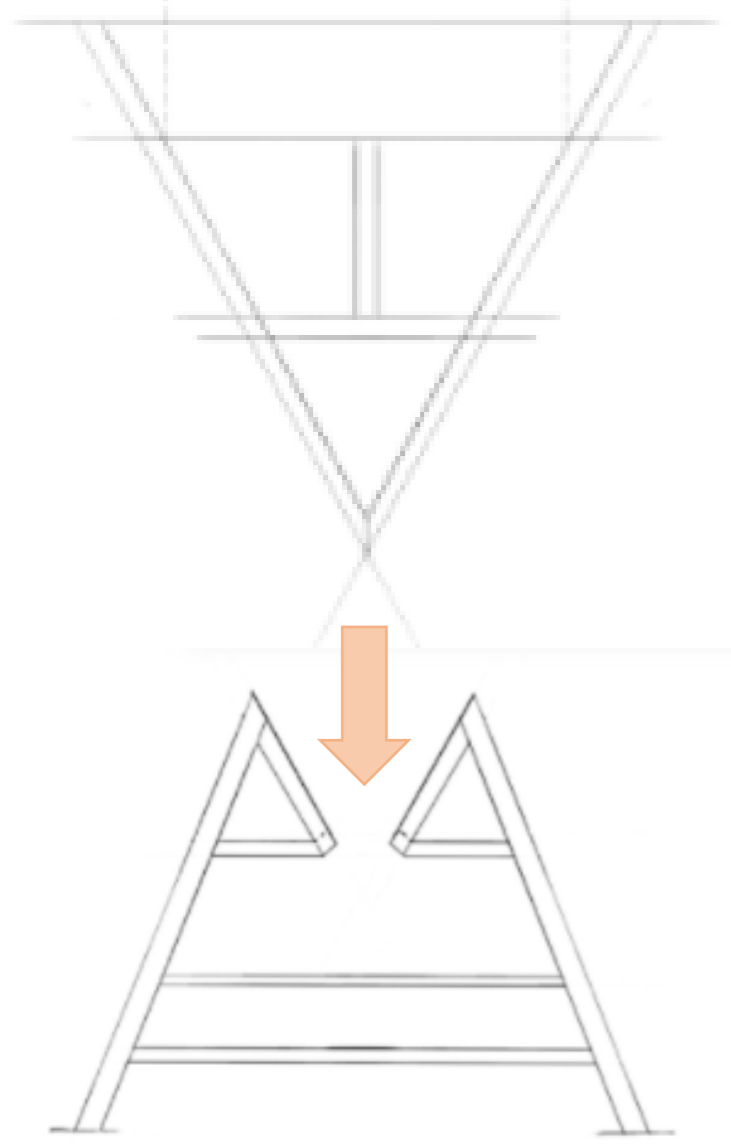

**Next steps:** write up a technical specification in full to allow me to have a final design all drawn up and ready to build.

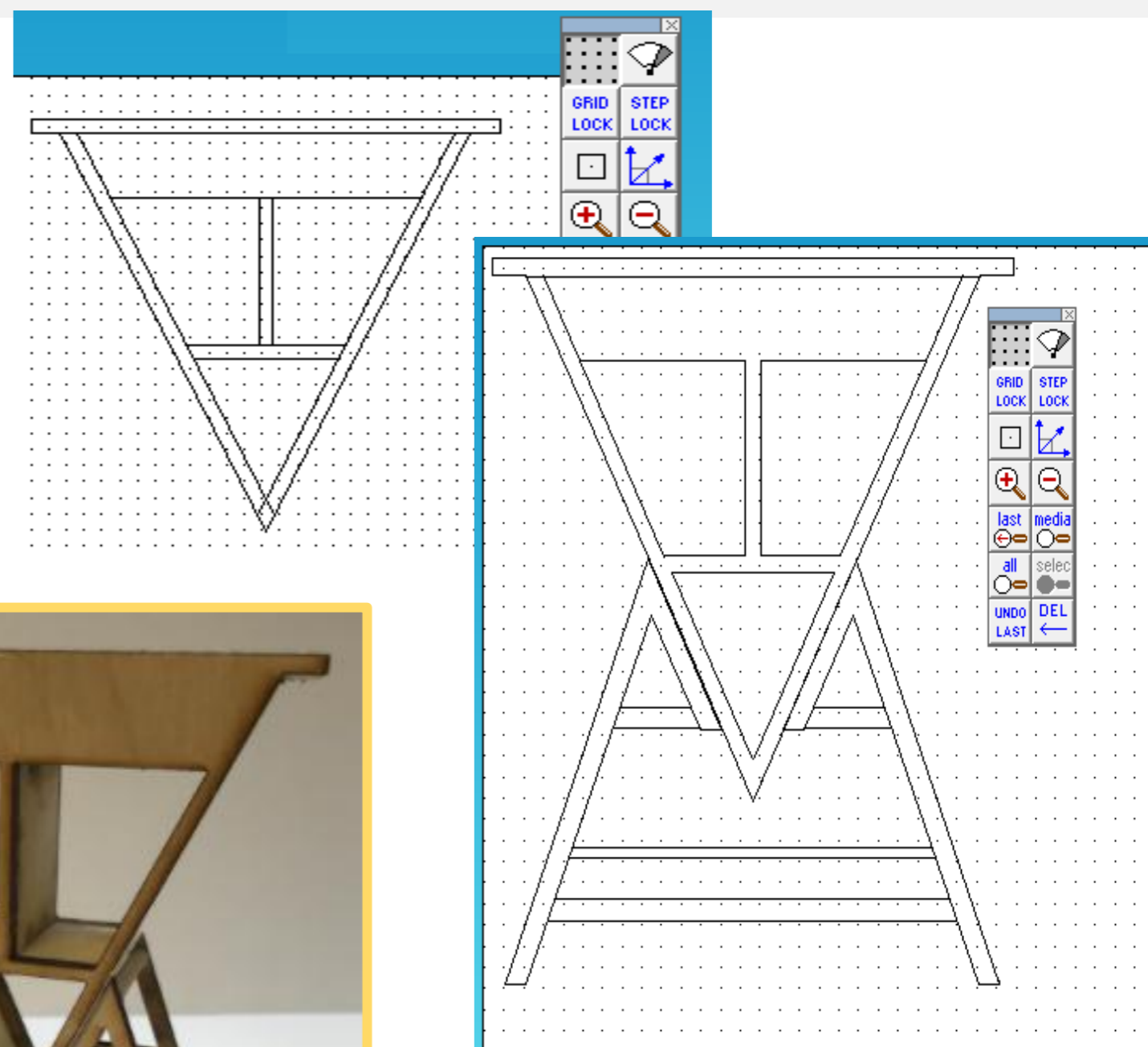

A 2 piece bed-side storage unit with 3 open shelves and a closed storage top made accessible by a moving hydraulic hinge.

Technical Specification

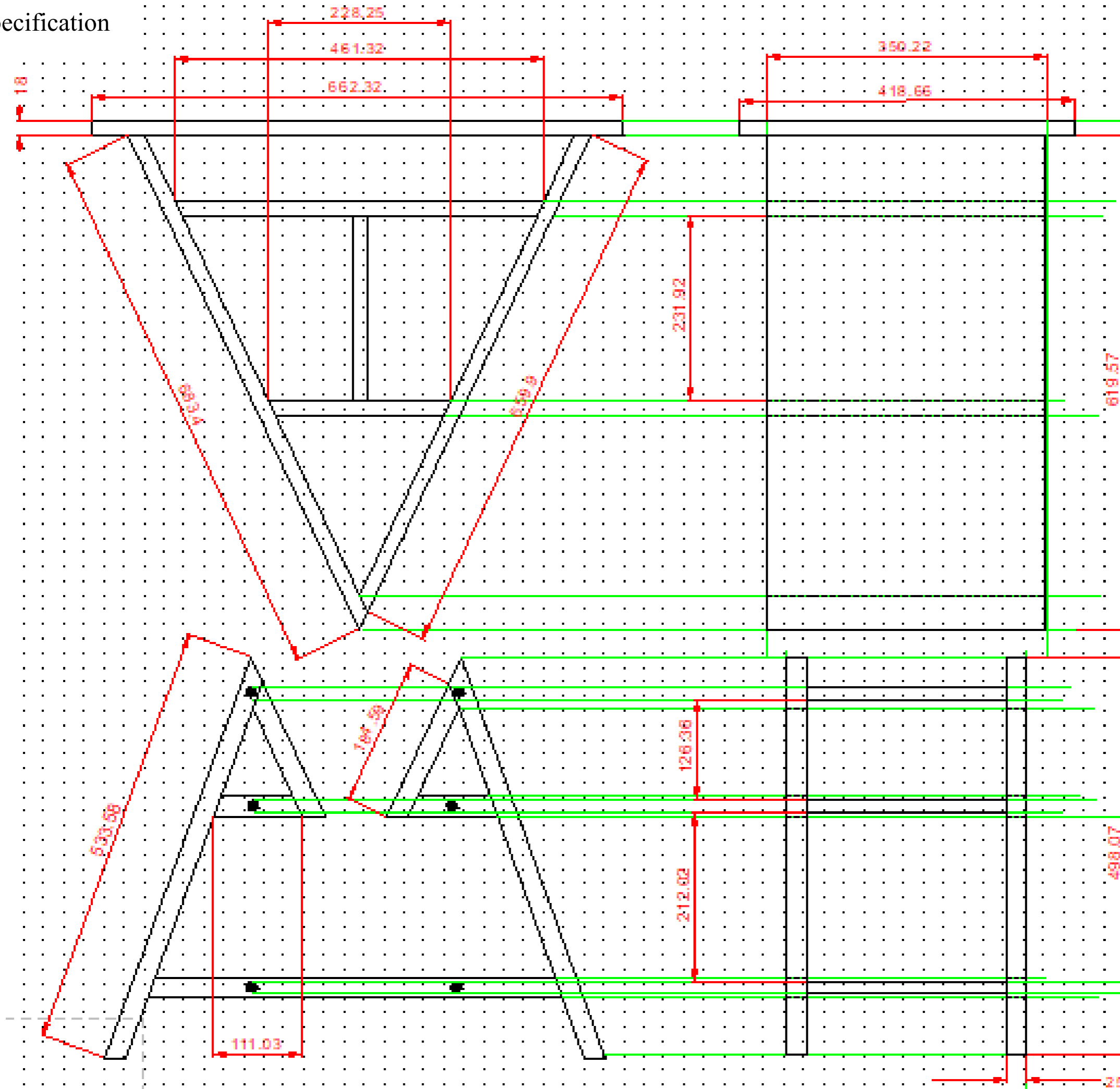

A vertical toolbar from a CAD software application, containing various icons for editing and drawing. The icons include a mouse cursor, a line tool, a circle tool, a rectangle tool, a text tool, a dimension tool, a copy tool, a paste tool, a delete tool, and a zoom tool. The toolbar is located on the right side of the drawing area.

**Next Step:** Work out a plan of making for manufacturing a finalised prototype of this design.

# Plan of Making



## Step and process in action      Health and safety considerations      Quality control checks

Using the scribe I will mark out lengths with a 3mm tolerance extension to account for the blade width of the circular saw, a degree of human error when measuring and some shortening from filing.



Measure and mark out where all dimensions of the 25mm square mild steel bars. For this I will use set squares, protractors and a metal scribe. Using these markings I will use the circular saw to cut out these bars, with the correct angles.

Goggles and ear defenders must be worn when using the circular saw as it is extremely loud and high pitched and metal fragments fly off unpredictably.

Must be careful not to touch the sharp edges and burrs of the mild steel before or during filing as they can cause metal splinter and cuts and scrapes.

I will clean up the jagged edges left on the mild steel from the circular saw because there will be many burrs that could give metal splinters. This can simply be done using a hand file.



I will constantly be checking against my scribed measurements to ensure that I get the filing to be as straight and accurate as possible. I will then re measure all of my pieces and correct any mistakes before going forward.

I will place all of my metal pieces into my required shape and make sure it all aligns flat and flush to each other before setting it in place with jig blocks to ensure they can't move out of position when brazing.



Using my bars, I will create a jig to use when brazing. I will use a board from previous projects and hot glue gun pre made jig blocks to it to accurately hold the bars in the place.

Must be careful when using the glue gun as the liquid glue that is released is extremely hot and can cause burns and blisters. So time and thought should be taken.

Tacking the mild steel together in the jig means that it can be removed and checked for being flat and squared properly before it is fully brazed together ensuring I can fix any mistakes made by human error at any stage.

Once marked, I will double check the measurements with a 3mm tolerance gap accounting for the width of the saw blade.

Measure and mark out the sides and flat shelf pieces of laminated pine from one 2400mm x 600mm board. I will use a tape measure, ruler, set square and pencil. From this I will set the band saw to the correct angles and I will cut out all of the pieces.



When moving the framework care must be taken as it is an odd shape with sharp corners meaning it could scrape you if not careful enough.



Send off my mild steel framework to be powder coated. It will get charged and then coated in dry powder by an electrostatic gun. The opposing charge attracts the coating to the metal. It is then heated to fuse it all together, sealing the finishing. It can then be used inside and out, anywhere you wish.

Packing the mild steel framework require bubble wrap and tape to secure it, reducing the risk of any damage from wear or knocks.

Blacked out goggles and an apron must be worn when brazing. This is because the light of the flame is so bright it can cause eye damage if not worn. It also uses a lot of heat so should be don't on/ surrounding non flammable materials such as stone and be conducted slowly and carefully.

I will brush flux onto the metal joints before brazing it together using a blowtorch to heat the area and melt a brass rod across the joints, sealing the joints strongly and securely.



Clean up all of the joints and framework using emery cloth and an angle grinder. This will smooth off all of the joints, giving it a sleek finish and allow the powder coating to be more even.

Goggles must be worn when using the angle grinder as sparks fly in all directions. It is also smart to wear long sleeves to protect your arms.



Time should be taken when using the angle grinder because it uses a strong force which could easily indent the metal.

Carries onto the next page

**Next Step:** Continue with the plan of making for the wooden frame in order to have a plan of making from start to finish.

# Plan of Making

Step and process in action Health and safety considerations/ risk assesment Quality control checks

I will use different sand papers with gradually finer grains so that all minor faults can be smoothed out and the wood can be soft to touch.

1 hour

I will use an electric sander to sand down my wood pieces to make the surfaces and edges smooth in preparation for joining them and ultimately adding finishes.

A face mask and goggles should be worn when using the electric sander in a well ventilated room to protect against the dust produced.

Goggles should be used when routing as dust is created and a cloth or brush should be used to apply the glue to protect hands against chemicals.

I will use ratchet straps to attach the exterior triangular framework together and mark out where the biscuit joint will go. I will use a biscuit router to cut the holes for the standardised biscuits to slot into. With this I will use wood glue to glue it all together using the straps to hold it in place.

2 hours

When it is all strapped together I will double check that all of the angles sit accurately and remain in place as it is glued.

I will mark out the location of the indent using a set square and will ensure that the 5mm depth stop is working before I set up a guide using clamps to ensure it remains straight.

I will then move onto the vertical shelf. For this I will use an electric router with a 5mm depth stop to route a straight indent on the two flat shelf for the vertical piece to slot into. Once routed I will use the same wood glue to glue them into place, using weights to secure them into place.

30 minutes

Goggles should be used when routing as dust is created and a cloth or brush should be used to apply the glue to protect hands against chemicals

I will measure out the angles from the wood and sketch a template from the framework to double check the angle before cutting it out.

The band saw requires goggles as sawdust is created and time should be taken to limit human error and enhance accuracy of dimensions.

I will then measure the framework to cut out the accurate sizes needed for the front and back panels of the top compartment. I will then glue it into place ensuring a sleek fit.

1 hour

I will be careful when placing the wood on the metal because if it hits the edge or corner of the mild steel it could easily scratch or indent.

With all of the components completed with their finishing's I will put it all together. This involves drilling and screwing the top piece to the closed compartment with the hydraulic hinge, then placing the wooden frame onto the metal frame before finishing it off by attaching the lights and charging port.

30 minutes

Care should be taken when using the drill as it could cause serious injury or damage to the product if too much force is exerted onto it.

I will use small amount of varnish at a time and will use wet and dry paper between layers to smoothen the surface and give it a cleaner finish.

2 days

Once all of the wood is cut out, sanded and attached together, I will use 50/50 varnish to coat the wood in 5 coats of varnish. This will seal off the product and protect it from damage from moisture and heat.

A cloth should be used to apply the varnish as there are chemicals that could damage the skin.

I will decide on the size and shape of the top piece and cut it out of the same board of laminated pine. I will then use a router to round off the edges of the piece.

1 hour

Goggles should be used when routing as dust is created and a cloth or brush should be used to apply the glue to protect hands against chemicals

I will make a template and see it against my frame to check that it works well before cutting it out of wood.

**Next Step:** using my plan of making, I will start making the final prototype for the bed-side storage unit I have designed.

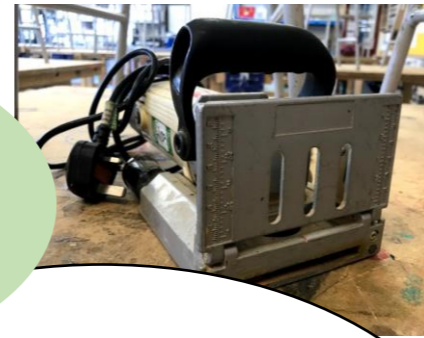

# Process of making

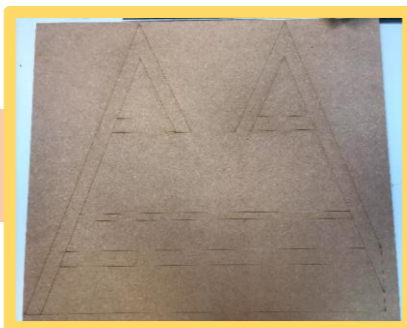
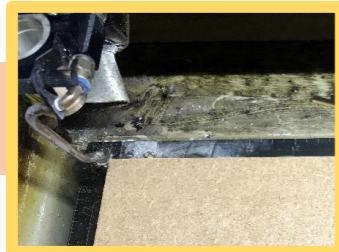
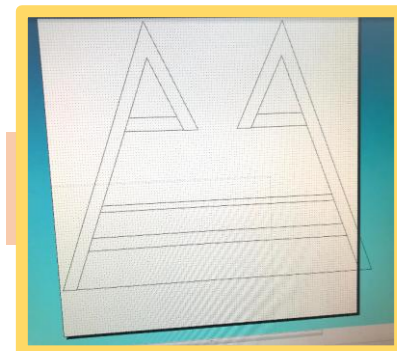

**3)** As I cut all of my pieces I repeatedly laid them out onto my template to ensure that they were accurate and I had not made them too short or uneven by human error.

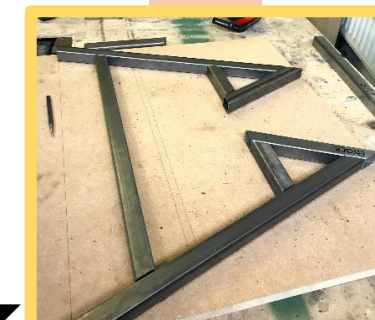

**2)** I started by using a scrap piece of metal to ensure that my calculated angles were accurate and would fit into the template. Once they were double checked as being accurate I used the Band Saw, set to the 50 degrees and then to the 25 degrees to cut out my lengths of 25mm square mild steel tubing.

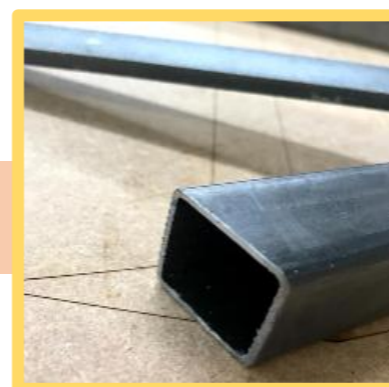

**4)** I used a flat edged hand file to get rid of the burrs that were created when I sawed my metal pieces down to size. This was sometimes awkward as it was hard to hold securely whilst filing it at the two angles but it was not too timely.



**5)** I then used a hot glue gun to attach small jig blacks to my laser cut template as I used the laid out metal pieces as a guide. It was at this point that I realised that I had cut some of my metal tubing wrong as I had cut the top corners of the M so that the open mild steel end would be on show rather than this being along the surface that the wood would it into.



**6)** I went back to the band saw and shortened four of the lengths of metal so I did not have to waste them. I did have to waste the four that I had cut too short unfortunately but I found a length of longer scrap metal that I used to cut out my longer pieces.

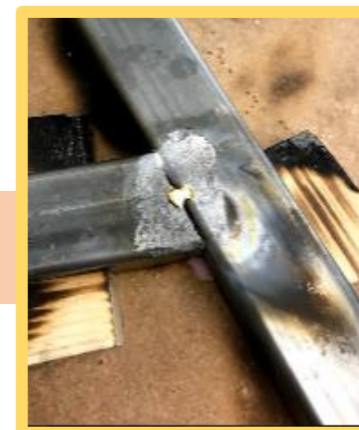
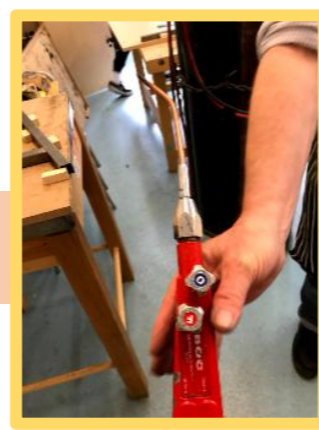
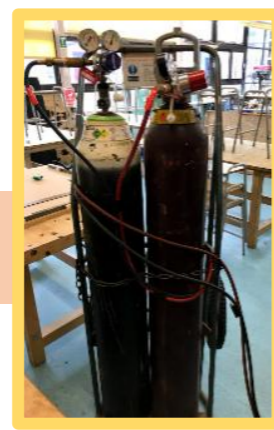

**7)** With my framework complete I prepared it all for brazing. This involved covering the joints with pink flux and getting the brazing equipment prepared (retrieving the gas canisters and blowtorch from their locked cupboard and practicing using a lighter to turn it on and quickly turning the torch off in case of emergencies. With this knowledge and experience I began to use a brass brazing rod to tac all of my two side frames together, on both sides with the same jig. This took a while and definitely got neater as I got used to the process

**8)** Once fully tacked, I compared the two side frames together to ensure that they are identical and did not need to change some of the positioning.



I continue to show my process of making on the next page.



# Process of making

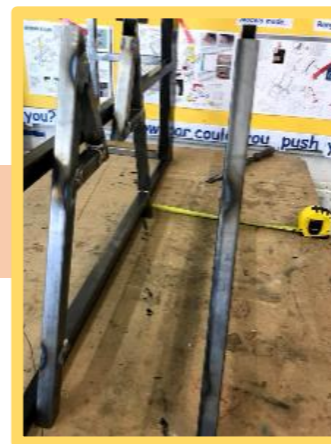
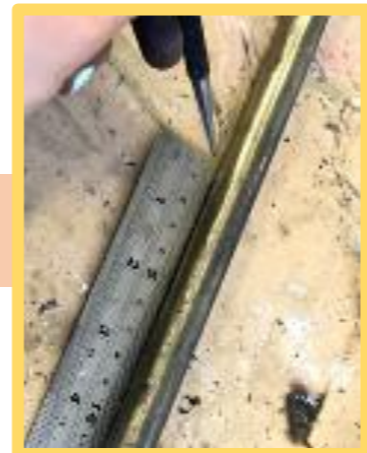
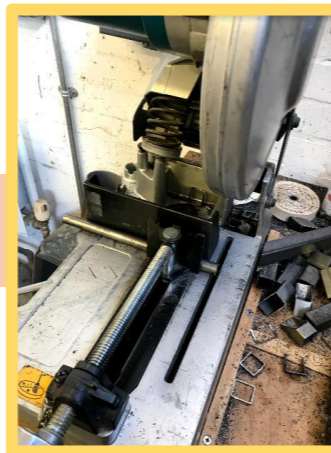
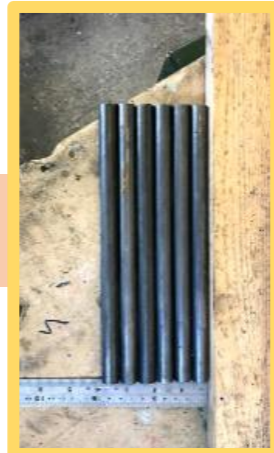

**10)** I decided on 240mm as my chosen length for my side beams. I used a scribe and a metal ruler to mark these onto the 16mm round mild steel tubing and used the band saw to cut them out, whilst checking between each one that they were measured to the exact same length to create an even frame that would be square. I then positioned them with the M frames to check that they all fit together well before they are put through brazing. The only issue I found was making them squared off at the ends because the bars are rounded so it was harder to judge so this slightly affected the quality later on. This however would not be an issue on an industrial scale as automated machines will be used to eliminate the human error.

**9)** I propped up the two side frames so that I could fiddle around with the width of the legs. I used a scrap round bar that seemed a good width alongside a measuring tape to decide on the exact width of my final piece. I did it this way because I could actually see everything in proportion so I could see whether different lengths would be feasible and appropriate for its suggested purpose. This was a trial and error attempt as it was better to physically see the frame with different widths compared to virtually on CAD software.

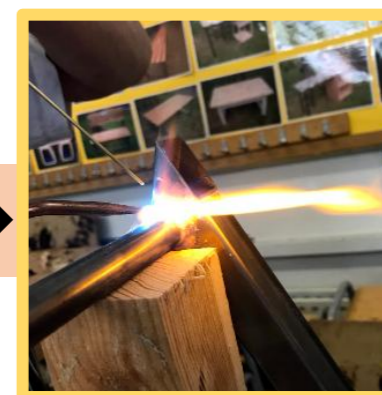
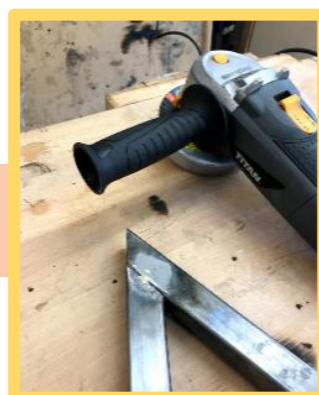
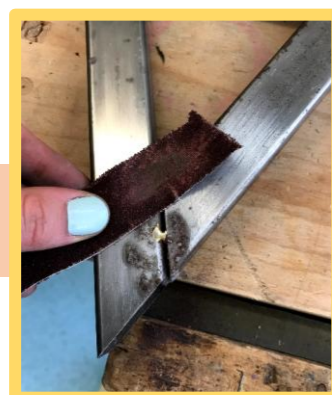

**11)** I used the circular saw to cut a piece of wood to 500mm tall so that the tallest connector pieces can have something to t on whilst they are being brazed into place.

**12)** I used an angle grinder to clean up the joints on the M frames near to where the newly cut round attaching poles are positioned so that I could tac the into place without any concern for the previous tacs and the quality of the new additions. I then used emery cloth to finish cleaning up the other joints and finish smoothening the grinded joints, especially in the places where the edge of the angle grinder could not fit into.

**13)** I used the acetylene and oxygen blowtorch to tac the tallest two support beams into place using the 4 wooden blocs I cut down to size earlier.

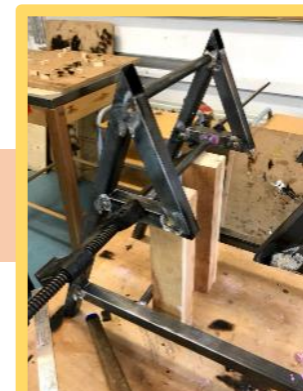
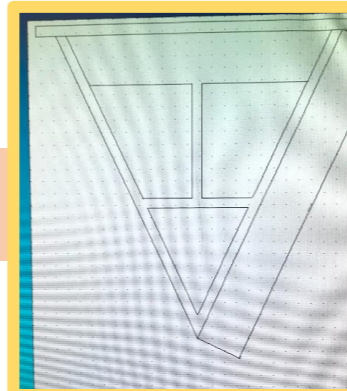
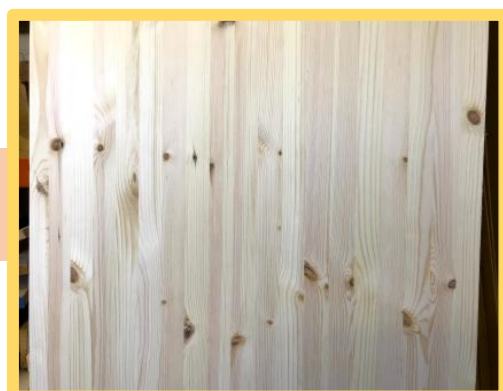

**14)** I went back to the circular saw to shorten my wooden pieces that I used to support the tallest connector piece so that the same support can be used for my shortest connector rod. I then tacked these in place with help of the wood.

**16)** I returned to my CAD drawings as a guide for starting to make my top storage component. After some deliberation I settled on making it out of wood to provide more material contrast and to ensure that the hydraulic hinge can be used in my design. I used two pieces of scrap wood to roughly see how this would look and help me firm my choice of laminated pine.

**15)** I then used the same process as steps 11-13 to tac the last two connector pieces towards the centre of the frame before using a large set square to ensue the whole framework sat square. **It was here that I realised that I had not cut the round tubes completely square on the band saw as there some unevenness in the degree of flatness of the tubing resting against the side frames.** Because I had only tacked the joints together I was able to hit it at different angles to make it more flat and squared.

I continue to show my process of making on the next page.

# Process of making

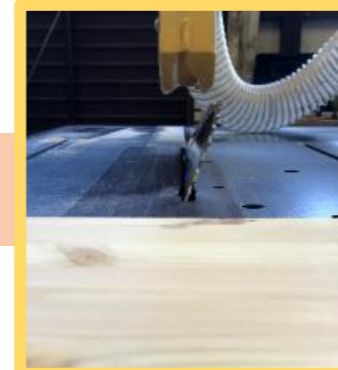
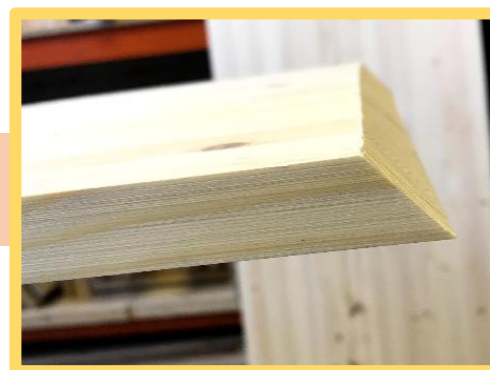
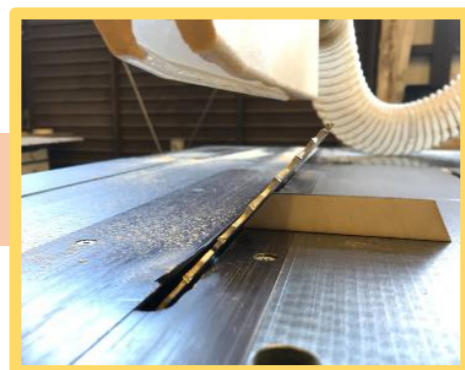
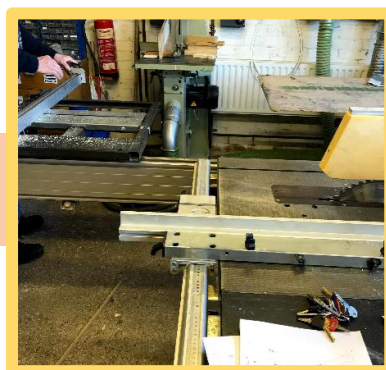

**17)** I took my piece of laminated pine and firstly measured and marked it out so that all of my main pieces, excluding the vertical shelf fit onto one 600 x mm sheet. With this I used the circular to cut the sheet in half width ways for the side and all pieces requiring a 300mm width. Then I set the circular saw to my 50 degree and later on my 25 degree angle using laser cut guides taken directly from my technical CAD drawings to cut all the remaining lengths that required the different angles to form the triangular frame. I then printed out my technical specification page to check that the measurements were all correct after being cut out using a tape measure.

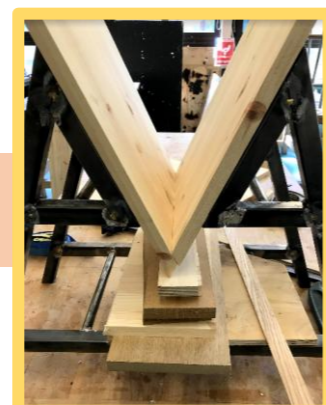
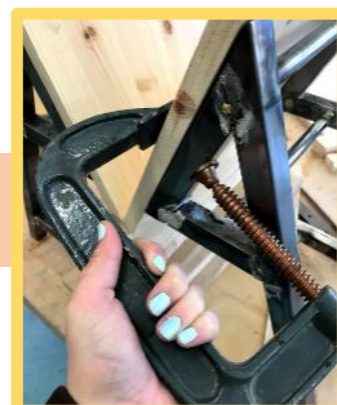
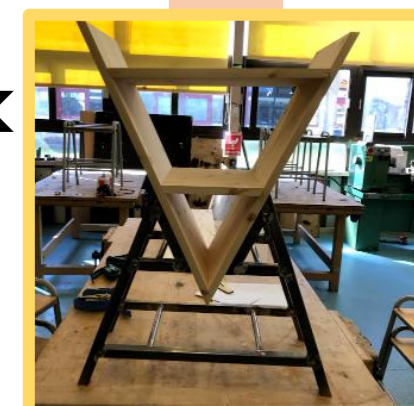

**18)** I took all of my pieces that I had just cut out and roughly placed them together in position before transferring them to the metal frame and positioning them again in order to visualise the product and check it all aligns.

**20)** Because of the failed attempts at strapping and clamping it in place I tried to use the metal frame to hold the wood in place using G clamps. To do this I collected pieces of wood to pile up on the metal frame to the level where the bottom point of the wooden triangle would sit in order to provide more support. However, once again this did not work as the G clamps could not sit flat against the wood due to the angled shape of the metal frame.

**19)** I tried to use wratchet straps to hold the frame in place in time for joining the wood. This did not go to plan as the wooden pieces kept slipping out of place as the straps were tightened due to the triangular shape. Because of this I tried cutting out smaller blocks of wood to G clamp them to the frame in places where it would stop the wooden sides from slipping however the block simply moved with the wooden sides.



**21)** I eventually found some suitable clamps in the form of clamps from a pasta maker machine as these were the only clamps that were small enough to fit in and around the small triangles at the top of the metal frame. Once clamped I used spirit levels to ensure that the shelves sit flat whilst lining up the base joint of the wooden frame.

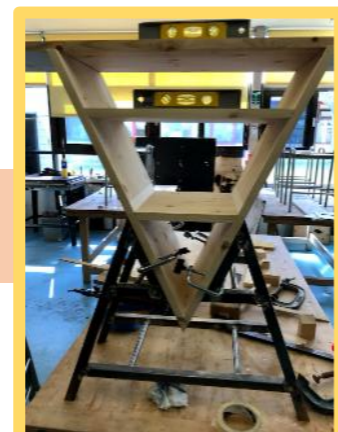

**22)** I used masking tape to prepare the base joint for gluing as I knew that this was going to be the hardest joint to get accurate before taping the rest of the joints at this point. I then compared my closed hydraulic hinge to the height of the top compartment to check if it would fit. I realised this space was too small for the hinge so I used the circular saw to shorten the top shelf by 2 cm in order to allow the compartment to be big enough for the hinge. I ensured this by comparing the new shelf against the hinge again.



**23)** I used wood adhesive with a small paint brush to cover the edges of the shelves and base joint that I was joining at that point. I used bricks to weigh down the shelves, making them more secure and strong. Using a damp cloth I cleaned up the excess glue along the joints before it set to give a better finish in the long run.

I continue to show my process of making on the next page.



# Process of making



**26)** Whilst the wooden frame was drying I took the opportunity to fully braze the metal framework. As the wood dried I only brazed the joints that faced away from the wood or was not near the wood so it did not get burnt and I then finished it off once I had removed the wood from the clamps.

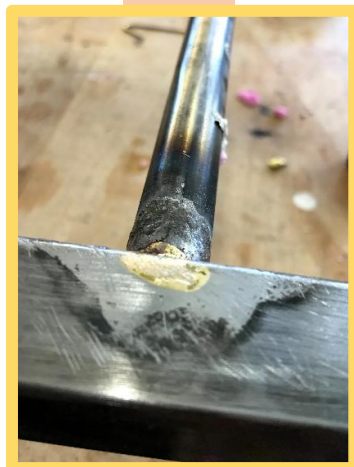
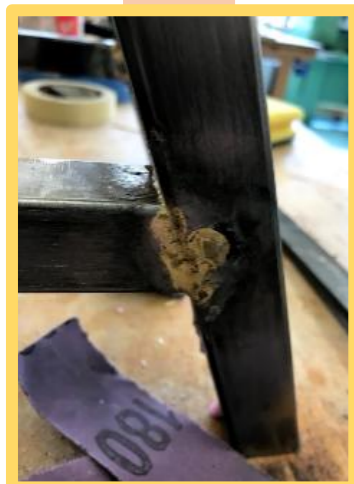

**25)** I then used the same process as in step 23 where I used the same wood adhesive and bricks to glue the side panels to the frame. I placed a scrap piece of wood across the top of the frame, from front to back (crossing over the panels with the new joints) in order to have a place to weigh down the joint using the bricks.



**24)** I used a scrap piece of MDF to measure out and see how the closed compartment would be comprised. I was able to cut the 25 degree joint into the MDF to put in place and ensure a sleek fit with the already made wooden frame. This was then traced onto a piece of laminated pine to ensure that the measurements and dimensions remained accurate throughout the transfer between MDF and pine. I then put the pieces of laminated pine in place to visualise the nearly finished product and check for any fault before they are glued in place.



**27)** I used the circular saw to cut the top piece of wood to have a 50mm overhang on the sides and 20mm on the front side. With this I was able to balance the extended hydraulic hinge with the wood piece on top in able to see the what the finished product would look like and check that the top piece is a good size for purpose- use for a desk and bed side table so it cannot be too wide or too tall or too long. I then added in one of the lights to see how well they would work in this space. With it being stationary, the light remained on until I turned it off as they are motion sense.

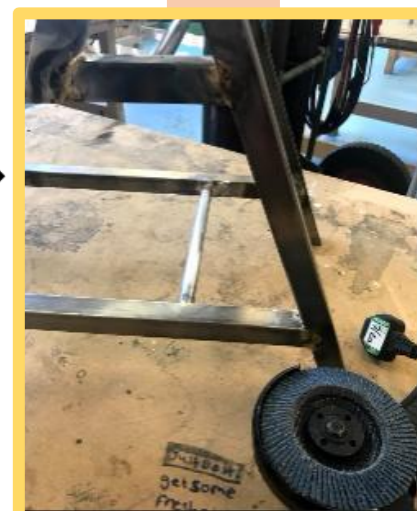
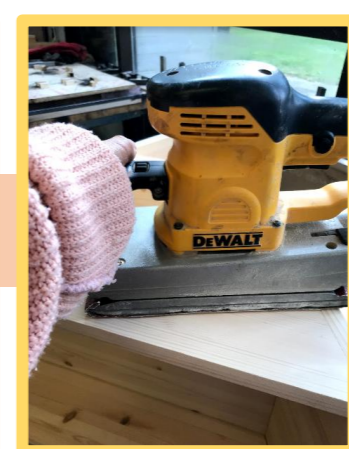
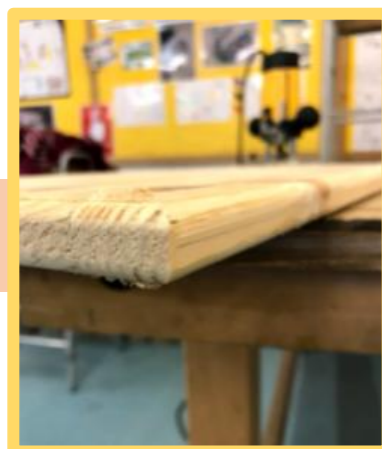

**28)** I used an angle grinder to clean up the brazing that I had done on my metal framework. At this point I decided to use a smooth finish hammarite spray to finish my mild steel rather than powder coating as time restraints make it easier. For this I put an order in for black satin smooth rite so once I had cleaned up my metal framework I put it aside to wait for the hammarite.



**30)** I kept the electric sander out for later and I used a round edged router to curve off the top and bottom edges of the top piece of wood for my piece. I adjusted the depth stop so that it was suited for my sheet of laminated pine, ensuring that the blade does not go too far into the wood.

**29)** I used an electric sander to sand down the wooden frame in preparation for its finishing's. To do this I lay it flat of a table at first and then I G clamped it to the edge of a table so that I could easily sand down the sides without it moving away from the sander due to it being on an angle. Soe of the joints such as the base joint of the wooden frame were not as clean so these areas required more attention with the sander.

I continue to show my process of making on the next page.



## Process of making

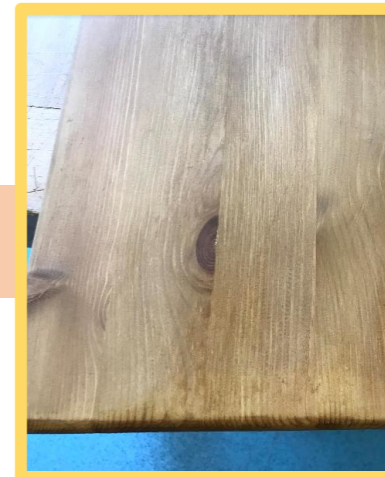
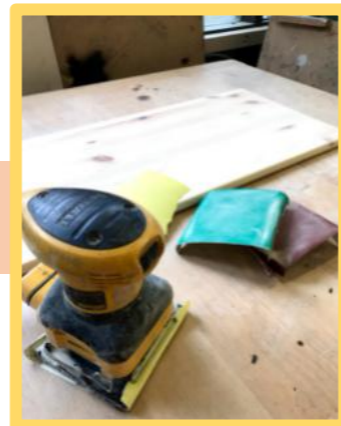

**31)** I used a sanding block to hand sand the routed edges of the top wood piece of my design. I used this method rather than an electric sander because of how thin the wood is and how unstable it would be if I used a vice because of the size of the laminated pine sheet. In industry this would be easier as a motorised machine could be set up to sand it quickly and efficiently. I then used the electric sander to sand down the top and bottom surface of this piece, working through the grains of sanding paper; brown being most coarse to yellow being least coarse.

**32)** I used antique pine water stain to stain the top wood piece I had just sanded. I applied the 2 coats with a scrap clothe using a small amount of stain with each dip. I made sure to cover the whole piece, doing the top, bottom and sides.

**33)** I then used a 50/50 varnish solution with another scrap clothe to finish off the top piece. I did 6 layers in total, letting it completely dry and using wet and dry paper to smooth off the layers between each one.

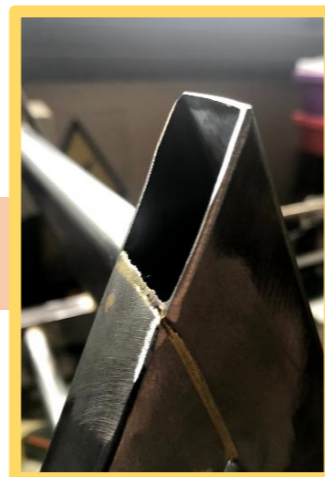

**35)** I then covered a work bench in news paper and started to spray my mild steel with satin black Hammarite. This took time as I needed 4 coats and needed to ensure that all the brass from brazing was covered. **On occasion I found myself being too heavy handed so in some areas drip streaks can be seen.**

**34)** I then returned to my metal framework because my order of Hammarite had arrived. I cleaned up my framework prior to my application by using an angle grinder to round off the remaining sharp edges and used a cloth dipped in white spirit to remove all grease from the surface.

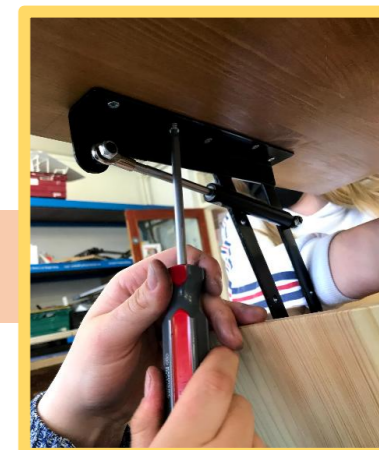
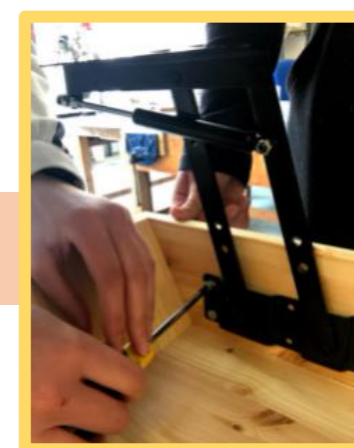

**36)** The last component to finish off was my wood. I used the same 50/50 varnish to coat the surfaces 5 times. Initially I varnished the inside of the hidden compartment, the bottom of the shelves and the two outer edges of the frame. I did this so that I was able to place it into the metal frame in order to varnish the rest of it as this seemed easier due to the odd shape.

**37)** Due to time constraints I decided to attach the top piece to the triangular frame with the hydraulic hinge as I could easily finish varnishing when I took the prototype to its destination. I used a pencil and marked the location where the 1/2" 6 screws needed to go. I then used a screwdriver, with help with holding the wood and hinge in the correct position to screw in the 26 screws to attach it all together. Due to the peculiar shape of the hinge some of the screws had to be screwed in at angles but this cannot be seen as it is on the under side.

I continue to show my process of making on the next page.



## Process of making



**38)** In order to give added detail and protection to my metal I took 20mm square bungs. I used a flat headed chisel alongside a mallet to cut 2 slits into the ridged side of the bungs so that this could be folded inside in order for it to smoothly fit into the angled frame. I did this for the 4 ends that make contact with the floor and the 4 open ends facing downwards from the tube that rests against the wood.

**39)** I then placed the wood into the finished metal so I could apply 5 coats of 50/50 varnish to the remaining surfaces- front, back, shelves and interior sides.



**40)** To finalise my design I used the sticky-back magnetic design of my motion censored lights to attach them to the wood. I originally planned to have one for each shelf/ compartment, however the base triangle shelf was just big enough to have one but was so small that it would have been wasted so I placed 2 on the side edges of the hidden compartment and one on the top of the top open shelf.

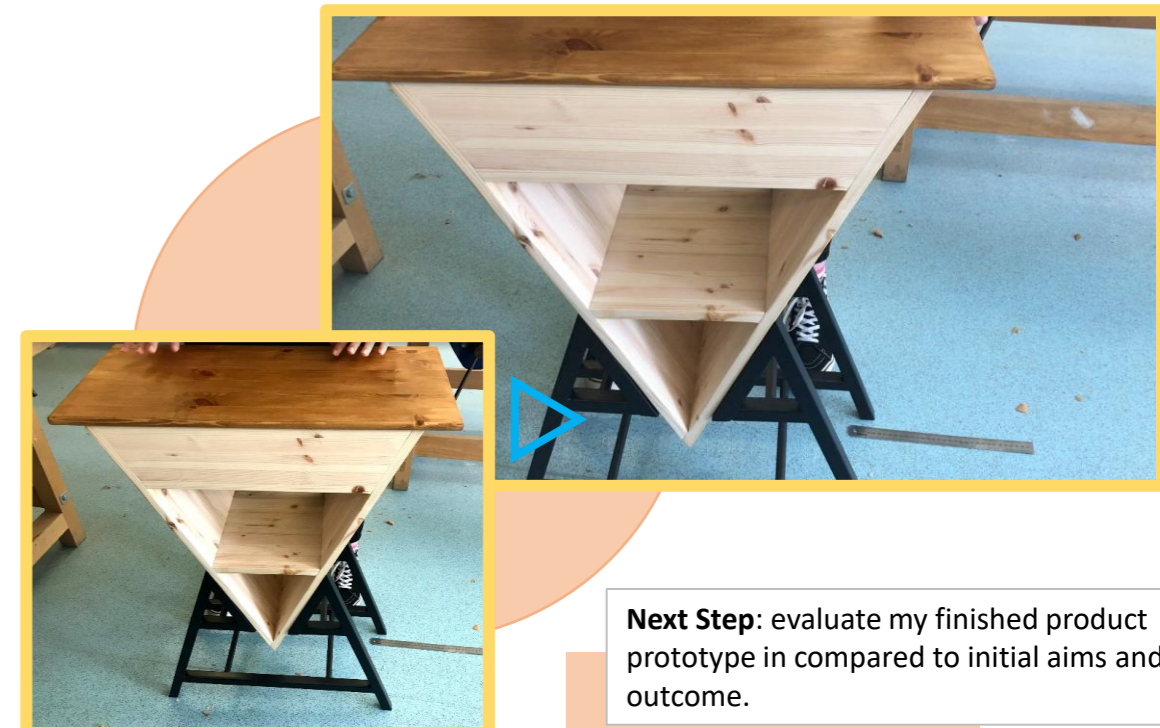

**Next Step:** evaluate my finished product prototype in compared to initial aims and outcome.

# Evaluating my prototype

Now that I have finished making my final prototype for my design solution I am going to start evaluating my product. To do this I have devised a table in which I planned out a feasibility tests considering different stakeholder wants and needs and how feasible my product would be in market.

My evaluation will incorporate my opinions and views as well as the thoughts and opinions of a range of stakeholders that have been involved throughout my iterative design process.

HOWEVER, due to COVID restrictions, my stakeholder interaction is limited as I cannot hold meetings inside with people outside my nose household. I will still obtain information from external stakeholders as I will devise questionnaires to pair alongside photographic evidence for them to analyse.

Who?	What?	Where?	When?	Why?	How?
<b>Manufacturers</b>	Construction techniques and finishes	How well it would work on an industrial scale		My one-off prototype is not representative of the design solution on market	I will analyse the prototype myself and get Callan Wintle, my external stakeholder to examine the feasibility for market
<b>Delivery services</b>	How would packaging work for transporting my design solution to its destination	It needs to be accessible to most locations including offices and houses	Ease of packaging- time constraints	It is a complicated shape so that could make packaging and transportation difficult	Acknowledging different possibilities and gathering opinions from stakeholders
<b>Marketers</b>	How well my final design solution will fit in competitive markets	Could my product and its USP fit in online and in store furniture suppliers	It should hopefully compete against current markets and possible improvements could compete in future	It needs to be marketable in order to make it feasible as a design solution	I will analyse similar products and compare them critically
<b>End users</b>	Physical testing in different contexts alongside in-depth user feedback	I will test my prototype in the position I am using it in and also for other uses and locations		To ensure that the prototype works well functionally	Using photos and video clips and annotating them with critical thinking notes
<b>End users</b>	Dimensions, weight, operation, and ergonomic analysis	In situ, at home where it is being used		To ensure that the prototype is feasible for general use safely and manageably	Using videos and photos to analyse the product in depth in terms of ergonomics



I did not include the vertical shelf. This is because when I was constructing the frame I realised that the horizontal shelves it would have sat between were rather thin so if I separated the shelf in 2 it would have reduced the efficiency of storage. It makes the design more open, allowing more light through, and reducing the number of lights needed.

Regretably, I did not have enough time to include the USB charging port because I have planned to make it 'in built' so that it would sit flush on the chosen surface (inside the private compartment). This was not possible due to the time constraints from having lockdown, reducing the time we were left with to make our prototype. Originally, I wished to use MDF/plywood to create a custom shelf which had the port built in, however I settled with a shelf of solid laminated pine.



I did not include a shelf on the metal framework. This is because when I placed the wooden framework on top of the metal one, the base of the triangle sits rather low in comparison to the horizontal mild steel support. This would mean that larger items would be disrupted by the wood, as well as reducing the 'tidy' look of the product. However, this is a component that can easily be added, making it a possible extension to the original product when marketed. This means that end users can make it more personal to them.



**Next Step:** conduct some physical testing on the prototype to analyse its feasibility as a product.

# Evaluating my prototype- physical testing

This highlights the issue of the lights being too sensitive.

As it is seen, the lights are triggered by nearby movement. During the night, this is problematic because moving in bed can activate the lights.

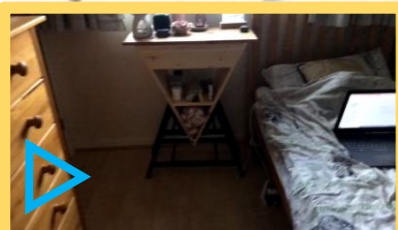

The lights in the closed compartment are arguably the most important as it is allowed to be cluttered due to it not being on display.

It also affects the private compartment as the lights can be activated whilst the compartment is closed.



This shows the illumination provided by the lights, notably on the open shelf where the light from the lights is bright, impacting the whole room, especially if the room is small.

The lights offer another dimension to displaying items which enhances the aesthetic and style of the piece.

This shows how the lights work.



Due to the light difference, as the top surface is raised, the lights are triggered.

This means that items can be hard to find unless well lit.

The lights are wireless and can be easily charged by USB cables.

It requires 2 hands, similar to the process of extending the hinge. However, it takes more force and a specific hand positioning in order to actually close the top surface safely and properly.

This limits the target audience as children and elderly adults cannot use the hinge to access the private compartment easily.

This video is a stark contrast to the next. It shows how the hinge retracts.

This process is much harder than the extension of the hinge.

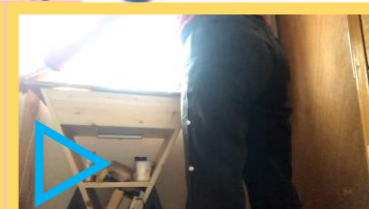
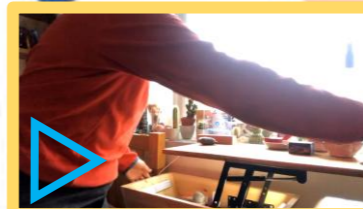

This video shows how easy it is to raise the top surface and extend the hydraulic hinge.

It doesn't require much effort or energy at all, just two sturdy hands.

This is a downfall as it cannot be raised easily with one hand, making it more inconvenient.

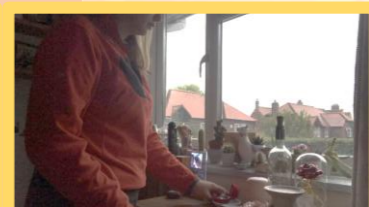
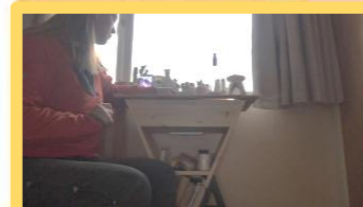

The height of the piece is appropriate for use as a desk as it is comfortable to write on.

The display shelf is quite low but is visible from a distance.

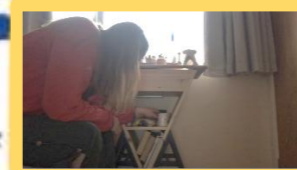

These photos show me using the product. It shows how it can be used when sitting and standing. This is due to the well thought through height.

My room is rather small so the addition of an external chair reduced the open space, making my room more claustrophobic.

This photo portrays the layout of my room as I tested the desk.

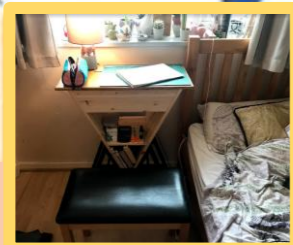

With this I showed that the large surface supports a large range of items without being cluttered.



As a mock display of a desk I set up my frame with a 40x35cm cutting mat, my round lamp and big pencil case in order to demonstrate how large the surface is.



I found that the best use of the bottom triangle in terms of aesthetics is that of storing soft items.

Another option for its use is for books placed on an angle along one of the edges.

This offers a unique style as the books will naturally sit at different heights, emphasised by the differing sizes of the books themselves.

This includes folded/rolled blankets and clothes such as jumpers, as seen in the photos.

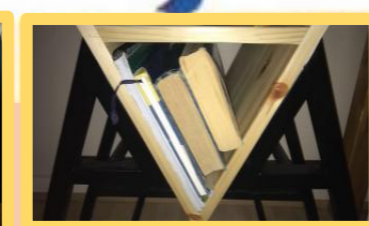
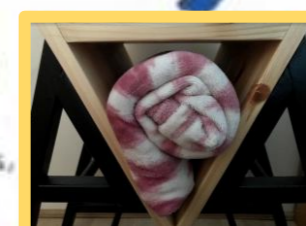

If it isn't filled completely, the covers are visible from the side. This allows easier use as the book can be selected correctly by the user without any hassle or confusion.

This photo shows how easy it is to use the frame as a desk, especially when sat down in front of the item.

It can be used when sat on a bed too!

This is because these items can be 'rounded' to the sharp angles which other items couldn't, for example square boxes and round items that roll.

Storing clothes here has the potential to be untidy but if they are neatly folded.

This can be time consuming to implement and maintain.

It adds a unique user input as their favourite books can be displayed, indicating their favourite genre and interests.

This photo emphasises how the top surface remains suitable as a desk when raised (the hydraulic hinge being extended).



When raised, the desk is accessible when standing.

This is because the hinge can hold a lot of weight including the pressure of a hand writing.

This adds another dynamic, allowing it to be utilised when sitting and standing.

The surface area of the top is large enough to support a large A4 folder when open, allowing larger stationary items such as schoolbooks and folders to be used and written in on top of the surface.



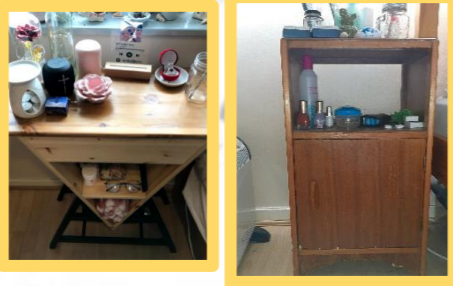
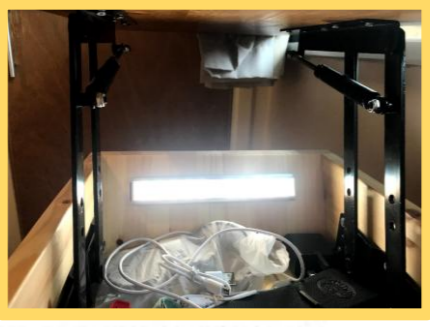
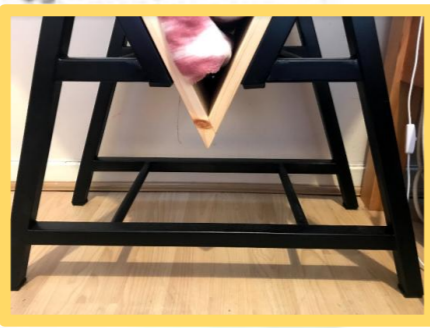
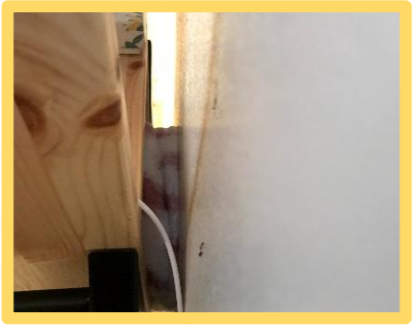
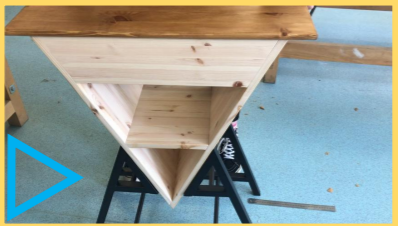

**Next Step:** analyse the overall strengths and weaknesses of my prototype and possible improvements I could make before presenting it to market.

# Evaluating my prototype

## Strengths

- My item is able to fit and store more belongings than my old storage unit whilst sitting in practically the same area of floor space, increasing the efficiency of solution used in this space. 
- It is taller than the average square bedside table with slanted sides so it is hard to hit your head on any side or corner.
- The private compartment can be accessed easily at night without aid from a phone or torch which may not be in the near vicinity. This is because of the addition of the lights on the inside, activated by the movement of the hinges. 
- It has a greater surface area, allowing for better displays and more efficient for storing technology and other items.
- The horizontal mild steel support can act as another shelf if necessary for the user. This can be done by placing an extra sheet of wood or planks of wood across the metal for more storage space. 
- This shelf / open metal frame allows for easy cleaning access to the floor, because it easily fits a duster and brush.
- Due to the overhang all around the triangle frame, notably the small one at the back, even when pushed right against a wall, all wires that hang off the shelf aren't damaged by being squashed them by the wall. 
- It is dynamic due to the moving hinge. opening a private compartment it adds interest to the design and gives items more privacy and safety. 

## Weaknesses

- The 50/50 varnish is unexpectedly affected by moisture and water meaning it leaves rim marks from drinking glasses. Due to this, coasters have to be used to protect the surface. 
- There is no USB charging port which neglects some of the user wants. This is not the worst impact as it is not crucial but it is still disappointing.
- The metal frame is wobbly in comparison to the wooden frame. This means that it does not sit flush, compromising the quality of the finish, as seen from the side of my prototype. 
- It can be rather tricky to close the hinge and requires some effort but with practice, the technique is simple.
- The wooden top surface doesn't sit flush onto the triangle frame due to human error when marking the position of the screws that attach the hinge in place. This can be seen from the front with a clear gap visible. 
- The use of Smooth rite for my metal finishing highlights the imperfections in my brazing and angle grinding.
- Some defects in the wood can be seen from wear damage when moving the wooden frame around. For example clear scratching and indentation can be seen on the front panels. 
- The lights are rather sensitive so the one from the open shelf often turns on with movement in the night (even from small movements not meant to trigger the light). 

## Improvements

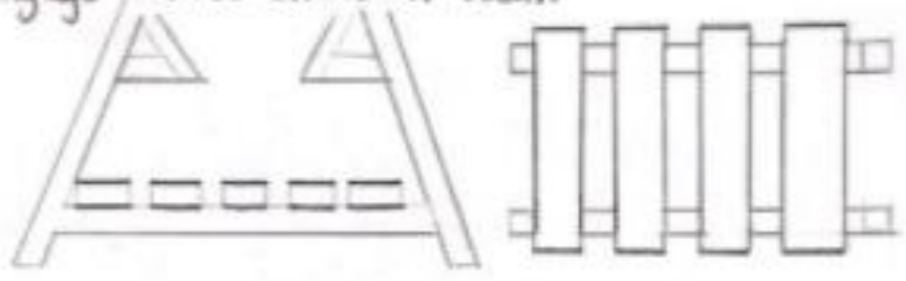
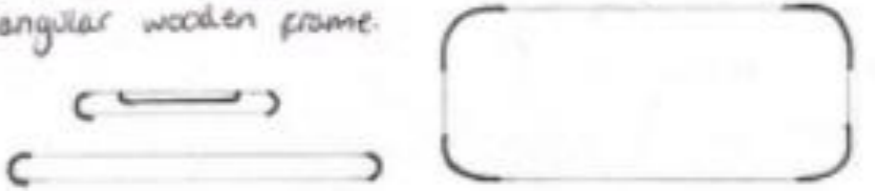
- Firstly, I would take more time over the construction. I would use bigger, more accurate, industrial machinery, to ensure higher quality and better dimensions. This could be achieved using CNC routers, automated machines and electric welders. As a result, all elements would sit flush together.
- I could lower the base metal supports and add an extra shelf to make use of the empty space. It would be comprised of multiple planks set perpendicular to the front view to maintain easy access to the floor. This could be used for larger belongings such as shoes or books. 
- I could improve ergonomics by using anthropometric data to curve the top surface and add grips to make it easier to raise/lower the surface in line with the hinge movements. This would impact the overhang of the product so that it could still sit flush with the triangular wooden frame. 
- I could use a similar routing technique to the previous improvement to make a small circular indent in the top surface that would act as a cup holder. This would make drinks more stable when the surface is in motion and reduce overall damage by water marks.
- I would include the USB charging port to the private compartment as I have discussed before. Alongside this I would add a wire organiser / pouch to allow spare wires to be stored safely.



**Next Step:** gather opinions from stakeholder by getting them to answer a few set questions once they have interacted with the prototype or from photos and videos.

# Evaluating my prototype- stakeholder feedback

I used my non- technical specification to devise a questionnaire for my stakeholders which I could easily analyse in terms of meeting user wants and requirements which is essential when marketing an innovative product.

**Non-technical specification:**  
Based off my research into stakeholder wants and needs over the last few pages, I will create a multi-functional product for a bedroom that MUST:

- ❖ Be space efficient
  - So that it can fit in smaller spaces making it efficient in most rooms, including smaller room sizes.
- ❖ Have a range of storage space
  - Including shelving and some closed space for storage of different items so people of different ages can make use of the product.
- ❖ Have a good quality of finish
  - So that users can confidently use the product without fear of easy damage and to allow it to be easily cleaned whilst keeping high quality aesthetics.
- ❖ Allow for technology to be used in conjunction with it with ease
  - Including power sources- sockets and a means of safely storing appliances so users can organise and efficiently store and charge their most used items.
- ❖ Offer both visual and organised storage space for safe keeps
  - So that most belongings, no matter the size or value may be safely stored without fear or loss or damage.

I ended up deciding on these 8 questions:

1. Would you use the prototype?
2. What aspects are your favourite?
3. What do you dislike about the prototype?
4. Is there anything you would change about it?
5. Do you like the finishing's I used, if not what would you prefer?
6. Would including the USB charging port make you more inclined to purchase the product?
7. Where could you see yourself using the product?
8. Is there elements that you would not utilise?

## Questionnaire for my stakeholders:

Stakeholder **Callan Wintle**

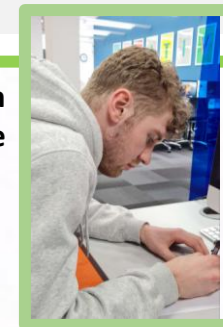

1. Would you use my product? **Yes**
2. What aspects of the prototype are your favourite?  
*the shape and unique style*
3. What do you dislike about the prototype?  
*how useless the base is in terms of storage*
4. Is there anything you would change about it?  
*I would find one for the metal frame - maybe more shelves*
5. Do you like the finishing's I used, if not what would you prefer?  
*I do but maybe the wood could be painted white to match the base*
6. Would including the USB charging port make you more inclined to purchase the product? **definitely**
7. Where could you see yourself using the product?  
*in my bedroom or office*
8. Is there elements that you would not utilise? **no**

## Answer analysis

- space efficient? **Yes**, but more storage could be added to the metal.
- range of storage space? **Yes**
- good quality finish? **Yes** but it should all match - wood + metal.
- use of technology in conjunction? **NO** really, the USB would make it.
- visual and organised space? **Yes** it is unique.

## Questionnaire for my stakeholders:

Stakeholder **Martha Preece**



1. Would you use my product? **maybe**
2. What aspects of the prototype are your favourite?  
*how much storage it can hold*
3. What do you dislike about the prototype?  
*how its hard to open*
4. Is there anything you would change about it?  
*make it lighter*
5. Do you like the finishing's I used, if not what would you prefer?  
*no, I would paint the triangles grey*
6. Would including the USB charging port make you more inclined to purchase the product? **Yes**
7. Where could you see yourself using the product?  
*living room*
8. Is there elements that you would not utilise? **no**

## Conclusions:

Key: **+** = My prototype has met the specification  
**-** = My prototype has not met the specification

- ❖ Space efficient? **+**
- ❖ Range of storage facilities? **+**
- ❖ Good quality finish? **+**
- ❖ Use of technology in conjunction? **-**
- ❖ Visual and organised space? **+**

**Next Step:** look further into the opinions of stakeholders by seeing their interactions and analyse what they think.

## Questionnaire for my stakeholders:

Stakeholder **Joe Nisbet**



1. Would you use my product? **yes YES**
2. What aspects of the prototype are your favourite?  
*I like you can open it from the top*
3. What do you dislike about the prototype?  
*I dont like the black steel*
4. Is there anything you would change about it?  
*I would make the bottom triangle bigger*
5. Do you like the finishing's I used, if not what would you prefer?  
*I like the wood but not the black I would make it white steel*
6. Would including the USB charging port make you more inclined to purchase the product? **Yes**
7. Where could you see yourself using the product?  
*In my bedroom for storage*
8. Is there elements that you would not utilise? **NO**

## Answer analysis

- space efficient? **To an extent** but the metal could also be storage
- range of storage space? **Yes**, notably the hydraulic hinge.
- good quality finish? **It is good quality but not the right aesthetic**
- use of technology in conjunction? **the USB would enhance this.**
- visual and organised storage? **Yes**

## Questionnaire for my stakeholders:

Stakeholder **Charlotte Grove**

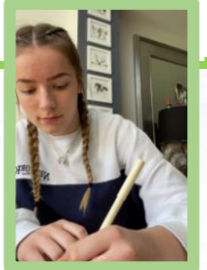

1. Would you use my product? **maybe in a house**
2. What aspects of the prototype are your favourite?  
*the cool angles and lights which turn on.*
3. What do you dislike about the prototype?  
*the little variety that can be stored in the base triangle.*
4. Is there anything you would change about it?  
*I would make the metal thinner than the wood.*
5. Do you like the finishing's I used, if not what would you prefer?  
*because the metal is black. I would prefer it all to be painted.*
6. Would including the USB charging port make you more inclined to purchase the product? **I would buy it as is.**
7. Where could you see yourself using the product?  
*in an office by a printer*
8. Is there elements that you would not utilise? **The base triangle.**

## Answer analysis

- space efficient? **Yes**
- range of storage space? **there is a range but little variety can be kept in it.**
- good quality finish? **Yes** but paint would be preferred.
- use of technology in conjunction? **Yes**, they would purchase it.
- visual and organised storage? **Yes!**

# Evaluating my prototype- stakeholder feedback

## Stakeholder James Sutherland interactions

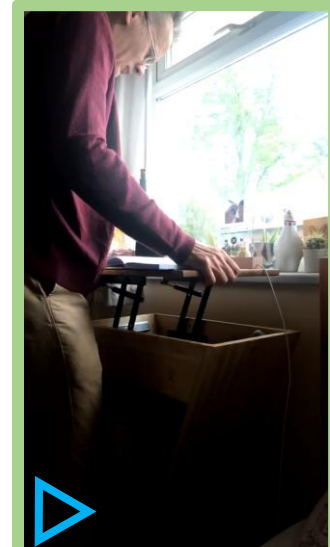

This video is James' first interaction with the hinge. He struggled with the control.

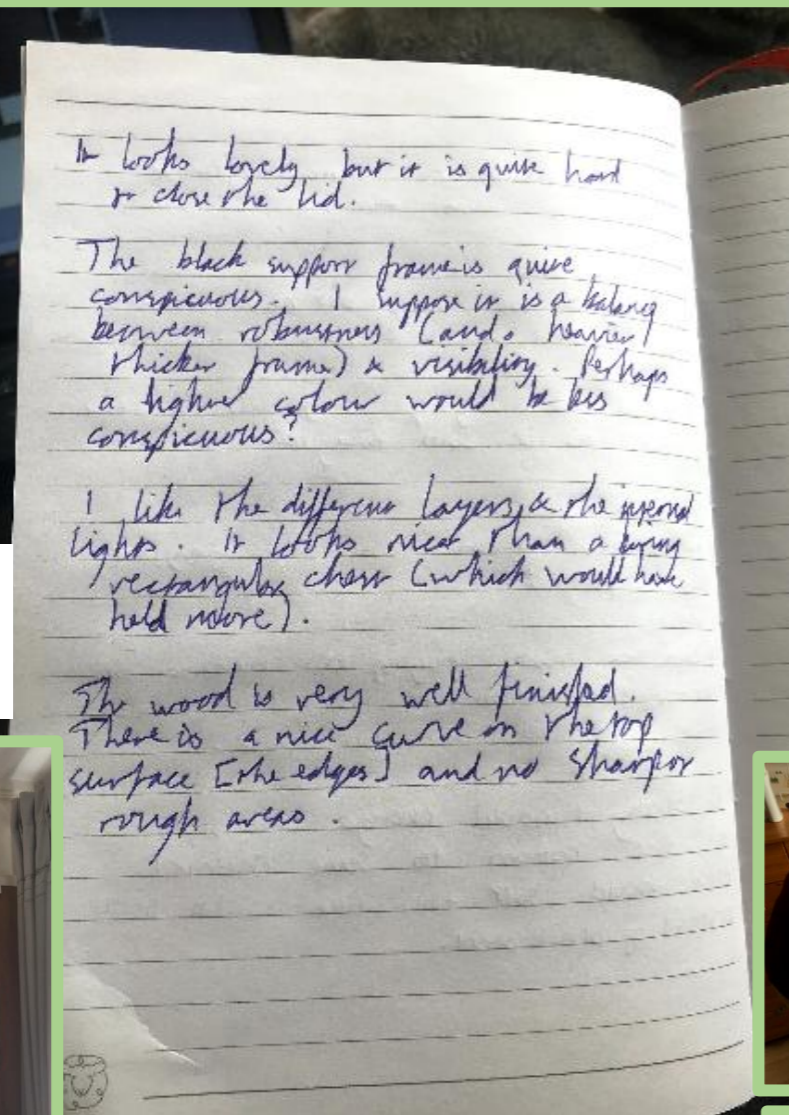

Overall, James likes my product as a whole but he thinks that improvements would have to be made to ensure that the hinge can be used with ease. Despite this, he is willing to pay £150 for a product of this quality.

James Sutherland answering two more financial questions that I had to gain a more detailed overview of possible pricing.

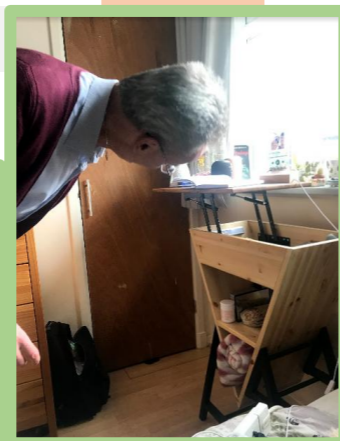

## Stakeholder Sophie Sutherland interacting and commenting on my prototype

Whilst Sophie highlighted her approval of my design solution being multifunctional as she thought that this is the aspect that would set it apart from other products. However, she made it clear that she did not like the mix of finishing's, notably the black metal. She would prefer if the finishing's match so wither all natural or all painted. This means that it would be more feasible on market if I had multiple options for finishes.

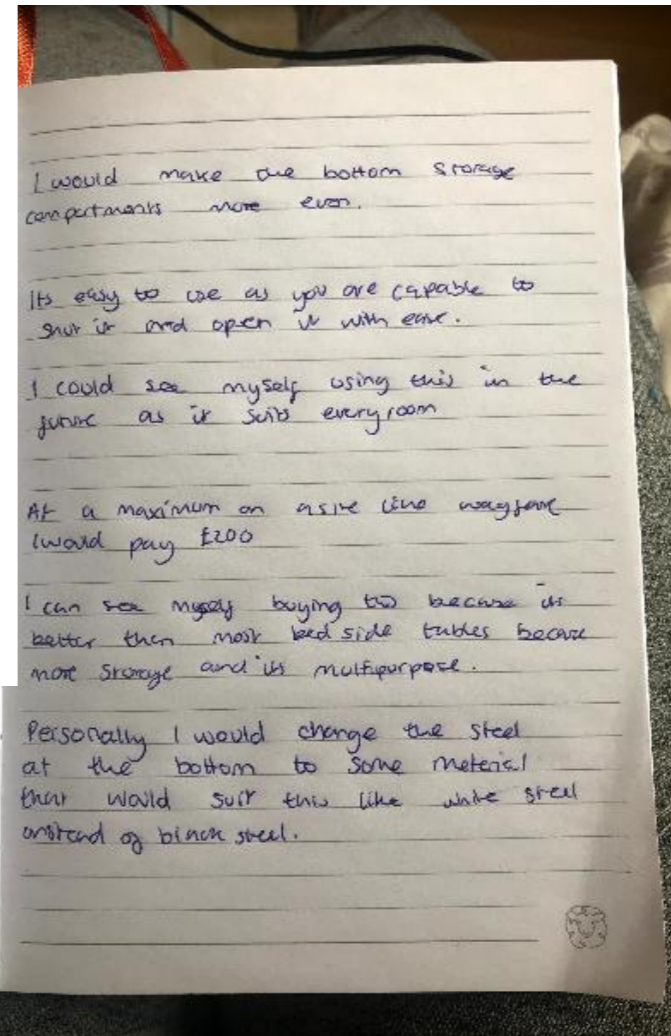

Overall, Sophie (who is a potential end user) liked the design stating that she would purchase the product for under £200. This ensures that it is viable as a product as I know that stakeholders are willing to buy it.

Sophie Sutherland answering two more questions that I had to gain a more detailed response from her.

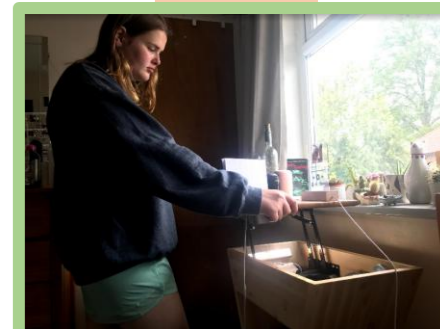

From this I can conclude that my product would be able to compete at a commercial scale as I have had 4 questionnaire responses and 2 interaction analysis profiles with different stakeholders with the overview that they would be willing to purchase and utilise my product. This means that I have a clear target audience that have expressed desire in my product which would make it viable.

**Next Step:** I will compare my prototype to existing products sold by 3 of my possible retailers.

Before I would put my product up for industrial construction I would improve multiple aspects based off my end user feedback. This would include:

- ❖ Improving the dynamic component so it moves smoothly without any effort required
  - ❖ This could include having a mechanism that would allow the hinge to raise when a downward force is applied to the top surface.
- ❖ Developing a range of options for people to chose from when purchasing. This would include different finishing's such as different colours.



To do these improvements I would utilise my prototype to run different tests and iterations to improve the smooth movements. This would include positioning the hydraulic hinge at different sites along the sides. I would then try different similar hinges to compare their qualities and suitability. Developing my range of finishing's will be a faster process as I simply have to decide in different combinations of paint colours, depths of stain and varnish finishing that work together aesthetically to enable the end user to make a decision of the overall look.

# Evaluating my prototype- existing products & marketing

This product has a square, perpendicular shape which is rather basic. It is a common characteristic of standard bedside tables which means that they don't stand out very well.

My product differs from HEMNES as mine has angled, slanted sides. This makes mine better in terms of visual impact.

In terms of empty space, both products are similar, neither is better due to the lack of storage throughout the whole design.

Similarly, my product lacks efficiency in the metal frame as there is no storage availability.

This product displays large, open, arguably useless space at the base by the floor.

In terms of materials, my product is better.

Both Ikea's HEMNES and my design solution have a top surface with an overhang indicating that this is desirable.

Both products have one flat shelf and one closed compartment but mine has a dynamic hinge.

My product is made from 2 materials with 3 different finishes. This gives better variety and interest.

This design is all made out of one material with one white finish.



**IKEA HEMNES**  
Bedside table, white stain, 46x35 cm

A high table that is just as convenient by the bed as in the entrance or as a side table by your favourite armchair. Made from sustainably-sourced solid wood, like the other furniture in the HEMNES series.

<https://www.ikea.com/gb/en/p/hemnes-bedside-table-white-stain-20200456/>

Overall, I believe that my product would withstand this competitor because they have similar finishes with the natural effect but my product offers a larger variety of storage solutions with the addition of hydraulics to make the ease of use smoother whereas plain draws can be stiff and have no unique aspect to them. If users are looking for something small then yes, the Wayfair product is better off but for efficiency and aesthetics with a range of finishes from stained and varnish natural wood to black satin Hammarite my product has many more benefits. My extended height, odd shape and range of storage solutions standing on a compact floor area work to achieve great efficiency for a storage unit.

I used the three retailers that I chose when I was investigating the context- **IKEA, John Lewis and Wayfair**. I selected three products of a similar nature to compare against my design solution. This will allow me to conclude on the feasibility of my design as I will see how well it could compete in a very competitive market.



Overall I would say that my product might be on par in popularity with IKEA's HEMNES. This is because other than the shape of the design, the main features and components are similar between both, with one flat shelf and one closed component. The main difference is the shape and finished but the popularity of both is hard to assume because its based of what individual end users are looking for, for example some may be looking for a small, basic, discrete piece whilst others may need more storage and like the unique style.

Wayfair's product comprises of 2 draws which offers closed storage for a large quantity of belongings.

My product only has 1 closed compartment, with 2 open shelves. This offers a larger variety of storage.

In terms of shape, my product is better.

This product is shaped similar to the prior as it is very boxy. The difference is that this product has curved edges, adding another element of style.

My product is uniquely triangular, making it stand out from competition.



**wayfair** **2 Drawer Bedside Table**  
See More by **George Oliver**  
Description **£111.99** **4.8** 125 Reviews

This 2 Drawer Bedside Table makes a perfect stand for nibbles, drinks or a lamp. It will prove handy all over your home and is made from 100% solid mango wood and has a fine chestnut finish. It has curved edges which will fit into any home/living space. It also comes with 2 drawers that come with shiny brass knobs and 4 Scandinavian styled legs.

<https://www.wayfair.co.uk/furniture/pdp/george-oliver-2-drawer-bedside-table-hazm6488.html>

In terms of storage options, my product is better as it offers a better range.

In terms of height, my product is more efficient. (This product is rather short (70cm tall). This means that it is similar height to a typical bed.)

My product is much taller providing more storage in a similar floor space. It also means that it is a better height for a desk.

The legs of this product are subtly curved on a wood tone. This adds a soft touch to the natural style.

In terms of durability, the mild steel legs are better.

My product has 20mm square mild steel legs, formed into a shaped frame. The steel is more durable and strong.

This product has no protruding elements such as handles.

Similarly, my product has no protruding elements except the overhang of the top surface. This however is necessary for the function of the top compartment.

In terms of exterior aspects, both products have sensibly angled depth which sticks out of the design.

Similarly to the previous product I analysed, John Lewis' product has 2 draws. This means that once again my product remains better as it gives a broader range of storage solutions.

In terms of finishes, my product is slightly better with more variety.

Unlike the other products I have analysed, this product has 2 different finishes - varner and paint.

My product has a white frame dedicated to the metal legs. This makes it raised from the floor.

Similarly, my product has multiple finishes, but mine has 3 in total - 2 different wood finishes.



**JOHN LEWIS & PARTNERS ANYDAY**  
John Lewis & Partners Mix it Bedside Table, Natural/Gloss White  
**£70.00** **4** (4 reviews)

Our Mix it range offers the flexibility to create your own contemporary, self-assembly bedroom furniture. Italian designed and manufactured, this bedside table is supplied flat-packed and it's easy to put together. It's made from high-quality chipboard and MDF, with two spacious drawers that have integrated handles. The frame has a natural, oak-effect look and the drawers come in a selection of finishes.

<https://www.johnlewis.com/anyday-john-lewis-partners-mix-it-bedside-table/natural-gloss-white/p4973515>

In terms of legs, my product is raised whereas this is not.

Unlike many products of this type I have seen, this one is built off the floor with no legs. This makes use of all of the space it takes up - efficient.

Overall, I think that my product compares highly to ANYDAY by John Lewis. This is because ANYDAY is a small box with draws that rests on the floor whereas mine is a dynamic, quirky, taller design which incorporates an angular presentation with the advancement of technological features in the form of lights and a self supporting hinge. This means that my product has more elements that could attract a bigger audience as it does more than provide storage solutions but acts as a display case with lighting. I do however have to say that from a pricing perspective, ANYDAY is much more viable and budget friendly as mine would cost considerable more than £70, even upward of £100 more in such a renown company like John Lewis.

From this I can see that my product stands out from most that act as a bedside table because mine offers a range of storage options, uses a range of finishes and has a completely different look to the pieces I have analysed.

**Next Step:** focus on how I would advertise my product in order for it to stand out in competitive markets.

## Evaluating my prototype- marketing

I previously compared my design solution against similar products in the market from the retailers: **IKEA, Wayfair** and **John Lewis**. These are companies that would hopefully manufacture, sell and distribute my product if made at an industrial scale for market. However, this makes it clear that I would need to be able to upsell my product efficiently to compete in the furniture market.

Because of this, I am now focussing on how I would advertise my product so it stands out from others and stands a chance in industry circumstances.

### My Unique Selling Points:

- Aesthetics with a triangular wooden frame and geometric base.
- Hydraulic hinge to add movement and consequent fluidity to the piece.
- A private compartment that is only accessible when the hinge is extended.
- Motion sensor lights that light up the storage spaces, enhancing visibility and ease of use.
- Mixture of materials offer a deeper complexity and better visual interest.
- Mixture of finishing's from black Hammarite to stain to varnish to offer contrast.

## Furniture of the future

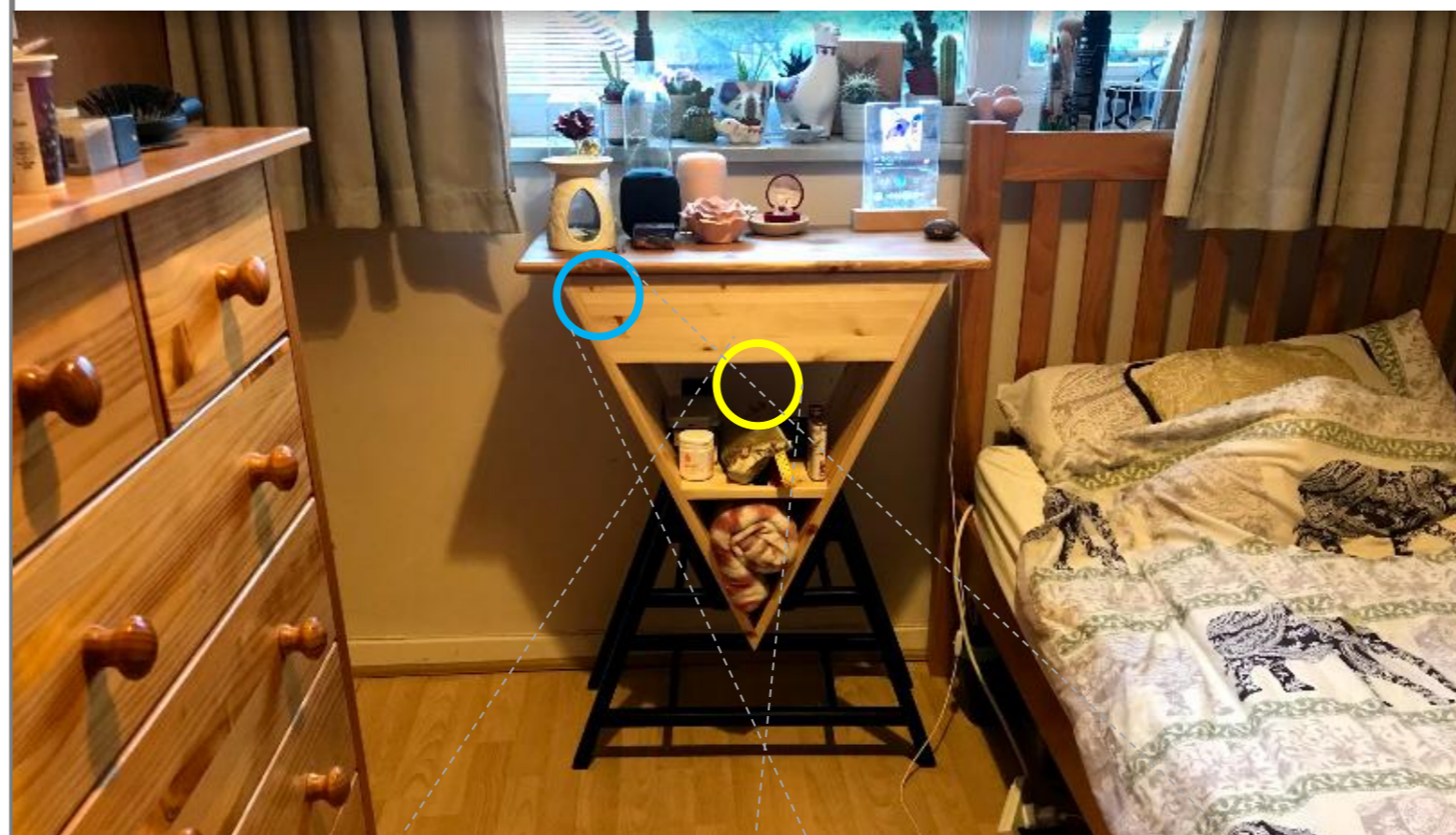

This abstract bedside table is a brilliant option for smaller bedrooms. Made predominantly out of laminated pine it has a natural, rustic look thanks to its varnished finish which is delicately balanced in a black mild steel frame with a gorgeous satin finish to complete the piece. Each piece is crafted out of wood sheets that ensure the natural grain is prominent in its unique irregularities to provide an authentic look. Convenient storage is given in the forms of two shelves and a large hidden compartment located near the top for owner access to enable privacy.

Now that I am able to advertise my product, it is feasible for market. Therefore, I am content with my piece and wish to evaluate the iterative process I used throughout my planning, designing and modelling.

### Evaluating the iterative process:

I used an iterative process throughout my design process whereby I repeated steps after changing and improving the outcome for my product.

Throughout my initial designs and design developments I worked alongside my stakeholders in order to iterate my design in concordance with their wants and needs. This allowed joint involvement and engagement with good communication between us in order to obtain the best outcome.

However, this came with its benefits and its struggles, including:

- ❖ It has made my prototype more viable in possible markets as it has ensured that my product is something that is desired above other products as it has been designed with end users in mind with unique features for them.
- ❖ The outbreak of COVID 19 meant that I was not able to get as much hands on discussion and interaction that I would have wanted to make it fully user focussed.
- ❖ It made me more confident in what I was doing with my designs and models, allowing me to test them better with more focussed aims of my investigations to obtain useful information to better the product for all stakeholders.
- ❖ I could have gathered more information from the stakeholders with them sat beside me when designing and developing my designs rather than after completing multiple developments and then gathering feedback to further develop. This would mean that the designs could bounce off one another's opinion on what could be better because I feel like the end users could have a more vital role in the progression of my design.
- ❖ The prototype I made reflects the wants and inputs of the stakeholders, meeting 4 out of 5 of my non-technical specification points. This means that on the most part my final design and prototype I made from this is a feasible product for the majority of my target audience.
- ❖ It was sometimes time consuming to wait for responses from external stakeholders as it was not in person so I had to chase up feedback for me to continue developing my designs. This is worsened by my small variety in my stakeholders. For my 3 key stakeholders I used 2 family members (one as an end user and one as a potential buyer) and one external lighting technician- Callan Wintle. This is a very limited range of people meaning I do not have the expert opinions and feedback from other stakeholders for a product of my type such as a furniture seller or manufacturer.

Overall, my iterative process of developing my design solution was positive as it allowed key involvement from multiple stakeholders in order to progress my solution with them as a focus. This can be seen through my physical testing and stakeholder feedback analysis which highlights the design as being feasible in market as it meets specifications.

Features	
Colour	Black/ brown
Metal frame material	Mild steel
Wood frame material	Sheets of laminated pine
Number of shelves	1 flat
Number of draws	None
Additional compartments	Private- exposed by dynamic hinge
Number of additional compartments	1
Country of origin	England
Assembly required	Yes
Volume	
Weight	35kg